



SP90m GNSS Receiver



User Guide



From Firmware v3.61

Legal Notices

©2017-2018 Trimble Inc. All rights reserved.

All product and brand names mentioned in this publication are trademarks of their respective holders.

SP90m User Guide, Rev. B, January 2018.

Limited Warranty Terms and Conditions

Product Limited Warranty. Subject to the terms and conditions set forth herein, Trimble Inc. ("Trimble") warrants that for a period of 2 years from date of purchase this Spectra Precision product (the "Product") will substantially conform to our publicly available specifications for the Product and that the hardware and any storage media components of the Product will be substantially free from defects in materials and workmanship.

Product Software. Product software, whether built into hardware circuitry as firmware, provided as a standalone computer software product, embedded in flash memory, or stored on magnetic or other media, is licensed solely for use with or as an integral part of the Product and is not sold. The terms of the end user license agreement govern the use of the Product Software, including any differing limited warranty terms, exclusions and limitations, which shall control over the terms and conditions set forth in the limited Product warranty.

Warranty Remedies. If the Product fails during the warranty period for reasons covered by this limited warranty and you notify us of such failure during the warranty period, we will repair OR replace the nonconforming Product with new, equivalent to new, or reconditioned parts or Product, OR refund the Product purchase price paid by you, at our option, upon your return of the Product in accordance with our product return procedures then in effect.

Warning to Users in the United States

Federal Communication Commission Interference Statement 47 CFR Section 15, 105(b). This equipment has been tested and found to comply with the limits for a Class B digital device, pursuant to Part 15 of the FCC Rules. These limits are designed to provide reasonable protection against harmful interference in a residential installation. This equipment generates, uses and can radiate radio frequency energy and, if not installed and used in accordance with the instructions, may cause harmful interference to radio communication. However, there is no guarantee that interference will not occur in a particular installation. If this equipment does cause harmful interference to radio or television reception, which can be determined by turning the equipment off and on, the user is encouraged to try to correct the interference by one or more of the following measures:

- Reorient or relocate the receiving antenna.
- Increase the separation between the equipment and the receiver.
- Connect the equipment into an outlet on a circuit different from that to which the receiver is connected.
- Consult the dealer or an experienced radio/TV technician for help.

The SP90m complies with Part 15 of the FCC Rules. Operation is subject to the

following two conditions: (1) This device may not cause harmful interference, and (2) this device

must accept any interference received, including interference that may cause undesired operation.

No Unauthorized Modifications

47 CFR Section 15.21

CAUTION: This equipment may not be modified, altered, or changed in any way without signed written permission from Trimble Inc.. Unauthorized modification may void the equipment authorization from the FCC and will void the Trimble warranty.

This device complies with FCC RF radiation exposure limits set forth for general population (uncontrolled exposure). This device must be installed to provide a separation distance of at least 30 cm from all persons and must not be collocated or operating in conjunction with any other antenna or transmitter.

Warning to the Users in the Canada

This device complies with Industry Canada RF radiation exposure limits set forth for general population (uncontrolled exposure). This device must be installed to provide a separation distance of at least 30 cm from all persons and must not be collocated or operating in conjunction with any other antenna or transmitter.

This device complies with Industry Canada licence-exempt RSS standard(s). Operation is subject to the following two conditions: (1) this device may not cause interference, and (2) this device must accept any interference, including interference that may cause undesired operation of the device.

Attention pour les utilisateurs au Canada

Le présent appareil est conforme aux niveaux limites d'exigences d'exposition RF aux personnes définies par Industrie Canada. Cet appareil doit être installé afin d'offrir une distance de séparation d'au moins 30 cm avec l'utilisateur, et ne doit pas être installé à proximité ou être utilisé en conjonction avec une autre antenne ou un autre émetteur.

Le présent appareil est conforme aux CNR d'Industrie Canada applicables aux appareils radio exempts de licence. L'exploitation est autorisée aux deux conditions suivantes: (1) il ne doit pas produire de brouillage, et (2) l'utilisateur du dispositif doit être prêt à accepter tout brouillage radioélectrique reçu, même si ce brouillage est susceptible de compromettre le fonctionnement du dispositif.

Europe



This product has been tested and found to comply with the requirements for a Class B device pursuant to European Council Directive 89/336/EEC on EMC, thereby satisfying the requirements for CE Marking and sales within the European Economic Area (EEA). These requirements are designed to provide reasonable protection against harmful interference when the equipment is operated in a residential or commercial environment.

Notice to Our European Union Customers



For product recycling instructions and more information, please go to <http://www.spectraprecision.com/eng/weee-and-rohs>.

Recycling in Europe: To recycle Spectra Precision WEEE (Waste Electrical and Electronic Equipment products that run on electric power), call +31 497 53 24 30 and ask for the "WEEE Associate". Or, mail a request for recycling instructions to:

Trimble Europe BV
c/o Menlo Worldwide Logistics
Meerheide 45
5521 DZ Eersel, NL



Declaration of Conformity

We, Spectra Precision, declare under sole responsibility that the product: SP90m GNSS receiver complies with Part 15 of FCC Rules.

Operation is subject to the following two conditions:

- (1) this device may not cause harmful interference,
- (2) and this device must accept any interference received, including interference that may cause undesired operation.

Explanations on logos and acronyms found on the receiver sticker:

FC : Federal Communication Commission

REACH : Restriction of Hazardous Substances Directive

CE : Conformité européenne (European Compliance)

WEEE : Waste Electrical and Electronic Equipment Directive

IC: Industry Canada

V: Volts

DC : Direct Current

Rechargeable Lithium-ion Batteries

This receiver uses one rechargeable Lithium-ion battery.

WARNING - Do not damage the rechargeable Lithium-ion batteries. A damaged battery can cause an explosion or fire, and can result in personal injury and/or property damage. To prevent injury or damage:

- Do not use or charge the batteries if they appear to be damaged. Signs of damage include, but are not limited to, discoloration, warping, and leaking battery fluid.
- Do not expose the batteries to fire, high temperature, or direct sunlight.
- Do not immerse the batteries in water.
- Do not use or store the batteries inside a vehicle during hot weather.
- Do not drop or puncture the batteries.
- Do not open the batteries or short-circuit their contacts.

WARNING - Avoid contact with a rechargeable Lithium-ion battery if it appears to be leaking. Battery fluid is corrosive, and contact with it can result in personal injury and/or property damage. To prevent injury or damage:

- If a battery leaks, avoid contact with the battery fluid.

- If battery fluid gets into your eyes, immediately rinse your eyes with clean water and seek medical attention. Do not rub your eyes!
- If battery fluid gets onto your skin or clothing, immediately use clean water to wash off the battery fluid.

WARNING - Charge and use the rechargeable Lithium-ion batteries only in strict accordance with the instructions. Charging or using the batteries in unauthorized equipment can cause an explosion or fire, and can result in personal injury or/and equipment damage. To prevent injury or damage:

- Do not charge a battery if it appears to be damaged or leaking.
- USE EXCLUSIVELY the dual-battery charger (P/N 53018010-SPN) or the AC/DC power supply (P/N 107000) to charge the SP90m Lithium-ion battery. See instructions in this guide. These two devices are part of the SP90m standard accessories list.
- CHARGE THE BATTERIES ONLY IN THE TEMPERATURE RANGE 0° to +40°C (32° to 104°F), at a maximum altitude of 2,000 meters (6,562 feet).
- Discontinue charging a battery that gives off extreme heat or a burning odor.
- Use the batteries only in Spectra Precision equipment that is specified to use them.
- Use the batteries only for their intended use and according to the instructions in the product documentation.

Disposing of the Rechargeable Lithium-ion Battery

Discharge the Lithium-ion battery before disposing of it. When disposing of the battery, be sure to do so in an environmentally sensitive manner. Adhere to any local and national regulations concerning battery disposal or recycling.

CAUTION - RISK OF EXPLOSION IF BATTERY IS REPLACED BY AN INCORRECT TYPE.

DISPOSE OF USED BATTERIES ACCORDING TO THE INSTRUCTIONS"

ATTENTION - RISQUE D'EXPLOSION SI LA BATTERIE EST REMPLACÉE PAR UNE BATTERIE DE TYPE INCORRECT.

METTRE AU REBUT LES BATTERIES USAGÉES CONFORMÉMENT AUX INSTRUCTIONS.

Receiver Use and Care

The receiver can withstand the rough treatment that typically occurs in the field. However, the receiver is a high-precision electronic instrument and should be treated with reasonable care.

CAUTION - Operating or storing the receiver outside the specified temperature range can damage it. For more information, see Physical Specifications in this guide.

High-power signals from a nearby radio or radar transmitter can overwhelm the receiver circuits. This does not harm the instrument, but it can prevent the receiver from functioning correctly. Do not use the receiver within 400 meters (1312 feet) of powerful radar, television or other transmitters. Low-power transmitters such as those used in cell phones and two-way radios do not normally interfere with receiver operations.



For more information, contact your Spectra Precision distributor.

Bluetooth & Wifi Radios

The radiated output power of the wireless radios is far below the FCC radio-frequency exposure limits. Nevertheless, the wireless radios shall be used in such a manner that the Spectra Precision receiver is 30 cm (11.8") or further from the human body.

The internal wireless radios operate within guidelines found in radio-frequency safety standards and recommendations, which reflect the consensus of the scientific community. Spectra precision therefore believes the internal wireless radios are safe for use by consumers.

The level of energy emitted is far less than the electromagnetic energy emitted by wireless devices such as mobile phones. However, the use of wireless radios may be restricted in some situations or environments, such as on aircraft. If you are unsure of restrictions, you are encouraged to ask for authorization before turning on the wireless radios.

COCOM Limits

The US Department of Commerce requires that all exportable GNSS products contain performance limitations so that they cannot be used in a manner that could threaten the security of the United States.

The following limitation is implemented on the receiver: Immediate access to satellite measurements and navigation results is disabled when the receiver's velocity is computed to be greater than 1000 knots, or its altitude is computed to be above 17,000 meters (59,055 feet). The receiver continuously resets until the COCOM situation is cleared.

Technical Assistance

If you have a problem and cannot find the information you need in the product documentation, contact your local distributor. Alternatively, request technical support using the Spectra Precision website at www.spectraprecision.com.

Your Comments

Your feedback about the supporting documentation helps us improve it with each revision. Email your comments to documentation_feedback@spectraprecision.com.

UHF Radios

Regulations and Safety. The receiver may be fitted with an internal radio as an option. It can also be connected to an external UHF radio.

Regulations regarding the use of Ultra High Frequency (UHF) radio-modems vary greatly from country to country. In some countries, the UHF kit may be used without obtaining an end-user license. Other countries require end-user licensing. For licensing information, consult your local Spectra Precision dealer.

Before operating the receiver with the UHF kit, determine if authorization or a license to operate the UHF kit is required in your country. It is the end-user's responsibility to obtain an operator's permit or license for the location or country of use.

Exposure to RF energy is an important safety consideration. The FCC has adopted a safety standard for human exposure to radio-frequency electromagnetic energy.

Proper use of this radio modem results in exposure below government limits. The following precautions are recommended:

- DO NOT operate the transmitter when someone is within 30 cm (11.8 inches) of the antenna.
- DO NOT collocate (place within 30 cm) the radio antenna with any other transmitting device.
- DO NOT operate the transmitter unless all RF connectors are secure and any open connectors are properly terminated.
- DO NOT operate the equipment near electronic blasting caps or in an explosive atmosphere.
- All equipment must be properly grounded according to Spectra Precision installation instructions for safe operation.
- All equipment should be serviced only by a qualified technician.

UHF restrictions in countries (Usable under license)				(As per article 10(10) from European Commission Directive 2014/53/EU)
				Belgium (BE), Bulgaria (BG), Czech Republic (CZ), Denmark (DK), Germany (DE), Estonia (EE), Ireland (IE), Greece (EL), Spain (ES), France (FR), Croatia (HR), Italy (IT), Cyprus (CY), Latvia (LV), Lithuania (LT), Luxembourg (LU), Hungary (HU), Malta (MT), Netherlands (NL), Austria (AT), Poland (PL), Portugal (PT), Romania (RO), Slovenia (SI), Slovakia (SK), Finland (FI), Sweden (SE) and United Kingdom (UK).
BE	BG	CZ	DK	
DE	EE	IE	EL	
ES	FR	HR	IT	
CY	LV	LT	LU	
HU	MT	NL	AT	
PL	PT	RO	SI	
SK	FI	SE	UK	

As per European Directive 2014/53/EU, all radio-frequency transmitting modules used in this product are listed below, together with their operating frequency bands and radiated power levels.

Module	Frequency Band	Power Level
UHF	410-470 MHz	+36 dBm
GPRS-3G, B I	1920-1980 MHz	+24 dBm
GPRS-3G, B VIII	880-915 MHz	+24 dBm
WiFi	2400-2483 MHz	+19.9 dBm
Bluetooth	2402-2480 MHz	+14.2dBm

These modules are all manufacturer-certified components, which were further tested in this product for full safety and compatibility with all the standards this product complies with.

Connecting the SP90m to an external battery using an SAE-terminated cable

The wires used should all be certified UL 758 and CSA C22.2 No. 210, or similar. Minimum wire section should be AWG 18, with insertion of a 5-A fuse in series. The fuse should be certified "UL listed" and CSA certified 3-30 A (or equivalent).

SP90m User Guide Release Notes, January 2018

The content of this new User Guide reflects the changes and enhancements made to the SP90m compared to the 1st edition of this guide (2017/06).

1. Enhanced and now multilingual user Interface. New features include most notably recording session control and choice of interface language. "Base mode" now reworded as "Receiver mode". All these changes are covered in chapter "Receiver User Interface".
2. New chapters are introduced to document some new or existing features. These are "Data Recording Sessions", "Embedded NTRIP Caster", "Embedded FTP Server", "Communicating with SP90m Using a Mobile Phone" and "Notification Emails".
3. SP90m only supports FAT32-formatted USB keys (page 10).
4. Port M refers to either the internal or an external memory (see page 17).
5. The Web Server now includes a horizontal banner providing a permanent, detailed report on how the receiver currently operates. This banner may be shown permanently, or simply hidden if not required. This new feature is mentioned on page 3, and described more in detail in the Online Help file attached to the Web Server's Home page.
6. Minor corrections (typos, inaccuracies, rewording) throughout the guide.

Table of Contents

Introduction to SP90m	1
First Steps	2
Unpacking	2
Basic Setup	2
Default Configuration	2
Customizing Receiver Operation	3
System Components Overview	4
SP90m Packout Kits.....	4
Standard Accessories	4
Country-Specific Power Cord.....	6
GNSS Antenna and Antenna Cables	7
Pre-Installed Firmware Options	7
Upgradable Firmware Options	8
Other Optional Accessories	8
Equipment Description	9
Front Panel	9
Rear Panel.....	11
SIM Card	13
Battery Model & Battery Compartment.....	13
Buzzer	14
Port Pinouts	14
USB Port.....	14
Power In, Serial Port A	15
Serial Port B.....	15
Serial Port F	16
Ethernet Port	17
Physical and Virtual Port IDs.....	17
Installation Instructions	18
Receiver	18
Tripod Mount.....	18
Bottom Plane Mount	18
Bumper Mount.....	19
GNSS Antennas Setup for Heading Measurements.....	19
Choosing the Appropriate Baseline Length	19
Elevation Offset	20
Azimuth Offset.....	21
Azimuth Offset, Antenna Setup & Resulting Heading.....	22
Delivering an RTK Position for the Primary Antenna.....	22
Powering the SP90m	23
External DC Source vs. Internal Battery.....	23
Power Mode	23
Charging the Internal Battery	24

Using an External Battery	25
Receiver User Interface	26
Welcome Screen	26
Using the Front Panel Controls	26
General Status	27
Radio	31
GSM	33
WiFi	34
Ethernet	35
Display Settings	36
Advanced Settings	36
Receiver Mode	39
Raw Data Recording	42
Power-Off Screen	44
Using a USB Key	45
To Copy Files	45
To Upgrade the Firmware	45
Getting Started With the Web Server	47
Introduction to the Web Server	47
Description and Function	47
Running the Web Server for the First Time	47
Security	47
WiFi-Based TCP/IP Connection	48
Setting Up the WiFi Device	48
Using the WiFi Device as Access Point	50
Using the WiFi Device as Client	50
Using the WiFi Device as both Access Point and Client	51
Ethernet-Based TCP/IP Connection	51
Setting Up the Ethernet Device	52
TCP/IP Connection Within a Local Network	53
TCP/IP Connection Through the Public Internet	54
Introduction to Multi-Operating Mode	55
Using SP90m With a Single Antenna	56
Specifying the Model of Antenna Used	56
Raw Data Recording	57
Using the Web Server	57
Working from the Receiver Front Panel	57
Autonomous or SDGPS (SBAS) Rover	58
RTK or DGPS Rover	59
Hot Standby RTK Rover	60
Trimble RTX Rover	61
RTK + Relative RTK Rover	63
Hot Standby RTK+ Relative RTK	65
Relative RTK Rover	67
Static or Moving Base	68
Using the Web Server	68
Working from the Receiver Front Panel	69
Using SP90m With Two Antennas	70
Specifying the Models of Antennas Used	70
SP90m Delivering Heading Measurements	71
Dual-RTK Rover	72

Dual-Relative RTK	74
Programming Data Outputs.....	76
Rover Output Messages	76
Base Data Messages	77
Raw Data Recording.....	78
Available NMEA Messages.....	79
Data Recording Sessions	80
Creating Sessions	80
Raw Data Types and Files Collected During Sessions.....	82
Storing G-Files Collected During Sessions	83
Converting, Compressing, Deleting G-Files Collected During Sessions.....	83
Moving Files Originating from Sessions	84
Pushing Files Originating from Sessions to a Primary FTP Server - Backup FTP Server.....	85
Recording Raw Data Outside of Any Sessions	86
Embedded NTRIP Caster	87
Introduction	87
NTRIP Caster Control & Monitoring	89
Protecting Mount Points	91
Embedded FTP Server.....	92
Communicating with SP90m Using a Mobile Phone.....	93
Introduction	93
Commands List	94
ANH: Setting Antenna Height	95
ANR: Setting Antenna Reduction Mode	95
ATH: Setting Anti-Theft.....	96
GETID: Reading Receiver Identification Information.....	96
GETMEM: Reading Memory Status.....	96
GETPOS: Reading Computed Position.....	97
GETPOWER: Reading Receiver Power Status.....	97
HELP: Reading the List of Commands	98
MEM: Setting Current Memory.....	99
MODE: Setting Receiver Mode	99
POS: Setting Reference Position	100
RADIO: Setting the Radio.....	101
REC: Setting the Recording Mode	102
SEND LOG: Emailing Log Files	103
SEND PAR: Emailing Receiver Parameters.....	103
Notification E-mails.....	104
Appendices.....	105
Specifications	105
GNSS Engine.....	105
Features.....	105
GNSS Sensor Performance.....	106
Precise Positioning Performance.....	107
Real-Time Performance	108
Post-Processing Accuracy (RMS)	108
Data Logging Characteristics	108
Memory.....	108
Embedded Web Server.....	108

User and I/O Interface	109
Physical and Electrical Characteristics	109
Environmental Characteristics	110
1PPS Output.....	112
Event Marker Input	113
Resetting the Receiver	113
Upgrading the Receiver Firmware.....	114
SP Loader Software Utility.....	114
Installing SP Loader	114
Getting Started With SP Loader	114
Upgrading Receiver Firmware	115
Installing a Firmware Option.....	116
Activating a CenterPoint RTX Subscription.....	117
Reading Receiver Warranty Expiration Date.....	117
SP File Manager Software Utility	118
Installing SP File Manager	118
Connecting SP90m to your Computer.....	118
Getting Started With SP File Manager	118
Establishing a Connection with the Receiver	120
Copying Files to the Office Computer	120
Deleting Files from the Receiver	120
UHF Networking.....	121
NMEA Messages.....	122
ALR: Alarms	122
ARA: True Heading.....	122
ARR: Vector & Accuracy.....	123
ATT: True Heading	124
AVR: Time, Yaw, Tilt.....	124
BTS: Bluetooth Status	125
CAP: Parameters of Antenna Used at Received Base.....	125
CPA: Height of Antenna Used at Received Base	126
CPO: Position of Received Base	126
DDM: Differential Decoder Message	126
DDS: Differential Decoder Status.....	127
DTM: Datum Reference	128
GBS: GNSS Satellite Fault Detection	128
GGA: GNSS Position Message	129
GGK : GNSS Position Message	129
GGKX: GNSS Position Message	130
GLL: Geographic Position - Latitude/Longitude.....	131
GMP: GNSS Map Projection Fix Data	132
GNS: GNSS Fix Data	133
GRS: GNSS Range Residuals	134
GSA: GNSS DOP and Active Satellites.....	134
GST: GNSS Pseudo-range Error Statistics	135
GSV: GNSS Satellites in View	135
HDT: True Heading.....	136
HPR: True Heading	136
LTN: Latency.....	137
MDM: Modem State and Parameter.....	137
POS: Position	138

PTT: PPS Time Tag	139
PWR: Power Status	139
RCS: Recording Status	140
RMC: Recommended Minimum Specific GNSS Data	141
SBD: BEIDOU Satellites Status	141
SGA: GALILEO Satellites Status (E1,E5a,E5b).....	142
SGL: GLONASS Satellites Status	142
SGO: GALILEO Satellites Status (E1,E5a,E5b,E6)	142
SGP: GPS Satellites Status	143
SIR: IRNSS Satellites Status.....	143
SLB: L-Band Satellites Status	143
SQZ: QZSS Satellites Status.....	144
SSB: SBAS Satellites Status	144
TEM: Receiver Temperature	144
THS: True Heading and Status	145
TTT: Event Marker.....	145
VCR: Vector and Accuracy	146
VCT: Vector and Accuracy	147
VEL: Velocity	148
VTG: Course Over Ground and Ground Speed	148
ZDA: Date & Time	148

Introduction to SP90m



The Spectra Precision SP90m is a powerful, highly versatile, ultra-rugged, and reliable GNSS positioning solution for a wide variety of real-time and post-processing applications. It also comes with a variety of integrated communications options, such as Bluetooth, WiFi, UHF radio, cellular modem, and two MSS L-band channels to receive Trimble RTX correction services.

The modular design of the SP90m allows for maximum flexibility on how the receiver can be used, such as base station, continuously operating reference station (CORS), RTK/RTX rover, for on-board machine integration, vessels, etc. The ultra-rugged design of the aluminum receiver housing protects the investment, especially in tough field environments.

The state-of-the-art and patented Z-Blade GNSS-centric technology uses all available GNSS signals to deliver fast and reliable real-time positions. Besides supporting all currently available and future planned GNSS satellite signals, the SP90m GNSS receiver allows the connection of two GNSS antennas for precise heading determination without the need for a secondary GNSS receiver.

First Steps

Unpacking

In its basic version, the SP90m is delivered with a transport bag, a Li-Ion battery, a dual-battery charger with battery inserts, an AC/DC power supply, a Bluetooth/WiFi antenna and accessories (see details in *System Components Overview on page 4*).

Additionally, a choice of GNSS antenna and coaxial cable should have been made, as well as that of a country-specific power cord.

When the chosen model of SP90m includes an internal radio, the power cable is different and a UHF antenna is added to the supply (see details on *page 4*).

Basic Setup

You may have the Li-Ion battery charged separately on the dual-battery charger (see *page 24*) or it can be placed in the receiver (see *page 13*) to be charged by the external DC source (AC/DC power supply) when connected as indicated below.

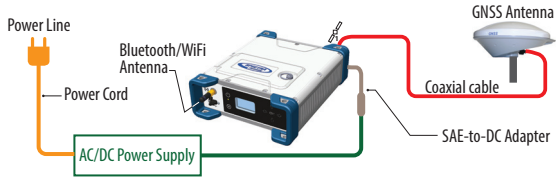

Default Configuration

The SP90m is shipped from the factory in the following configuration:

- Antenna configuration: Single antenna (GNSS input #1)
- Selected GNSS constellations and signals: All
- Elevation mask (for position and raw data): 5 degrees
- Anti-theft and startup protection: Both OFF
- Base Mode: OFF (the receiver will operate as a rover)
- Receiver with internal radio: Radio is ON
- GSM, WiFi: Both devices OFF
- Bluetooth, Ethernet: Both devices ON
- Raw data recording: OFF
- Internal GSM antenna is used
- Preset messages for raw data recording: ATOM (PVT, ATR, NAV, DAT, RNX-O, OCC)
- Distance unit used: Meters
- No corrections messages preset to be generated in base mode

- Screen orientation: Normal
- Screen timeout: 10 minutes
- Buzzer: ON
- Automatic receiver power-on and power-off: Disabled
- ATL Recording: OFF
- Access to Web Server: Protected. The default login is "admin" and the default password is "password". These may be changed using the **Security** tab in the Web Server.

Customizing Receiver Operation

- If you wish to change the configuration, you need to:
 - Run the Web Server: see *Getting Started With the Web Server* on page 47.



- Then choose your operating mode and follow the instructions to make it operational: See *Using SP90m With a Single Antenna* on page 56 or *Using SP90m With Two Antennas* on page 70.

The current status of the receiver can be seen at all times at the top of the window after clicking on .

NOTE: Web Server functions not described in this manual are covered in the on-line context-sensitive help.

- In all those applications where the *Spectra Precision Survey Pro* field software will be used, the configuration steps needed before operating the receiver in the requested mode may be taken directly from within *Survey Pro*. Typically in this case, a Bluetooth connection will be used between the data controller running *Survey Pro* and the SP90m.

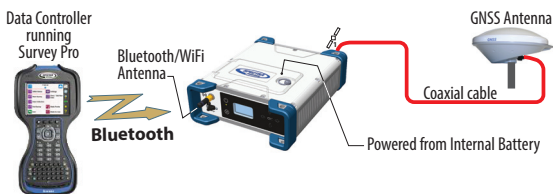

NOTE: Some configuration changes can also be made directly from the receiver's front panel. See *Receiver User Interface* on page 26.

System Components Overview

This section provides an overview of the different key items composing the SP90m.

Depending on your purchase and based on the type of survey you wish to perform, you may only have some of the listed items. Please refer to the packing list for an accurate description of the equipment that has been delivered to you.

NOTICE: Spectra Precision reserves the right to make changes to the items listed below without prior notice.

SP90m Packout Kits



Item	Part Number	Picture
SP90m, Survey, including standard accessories (see next table): <ul style="list-style-type: none"> • Worldwide use, without UHF radio • Worldwide use, with UHF radio • China only, without UHF radio • China only, with UHF radio • Latin America only, without UHF radio • Latin America only, with UHF radio 	<ul style="list-style-type: none"> • SP90M-101-00 • SP90M-101-60 • SP90M-101-00-20 • SP90M-101-60-20 • SP90M-101-00-50 • SP90M-101-60-50 	



Standard Accessories

The receiver you ordered was shipped with the following standard accessories. (If needed, each of these items may be



ordered separately as spare parts; Use the part numbers mentioned in the table below when ordering.)

Item	Part Number	Picture
Spectra Precision Transport Bag	206490-ASH	
Li-Ion battery, 7.4 V DC, 3700 mAh	76767	
Dual Battery Charger (does not include AC/DC power supply and cable)	53018010-SPN	
AC/DC Power Supply, 65 W, 19 V, 3.43 A, 100-240 V AC, Class VI (used either to power the receiver or the battery charger) (power cord not provided; see section below)	107000	
SAE-to-DC adapter cable, 0.15 m	88769-00	
OTG Cable, USB A to Mini USB B	107535	
Battery inserts for Dual Battery Charger (used for mechanical adaptation of the battery to the charger) (Qty: 2)	83664-00	
Helical SMA 2.4 Bluetooth/WiFi antenna, RH series	111403	
Tape measure, 3.60 m (12 feet)	93374	
Quick Start Guide	-	

For part numbers not including a UHF radio (SP90M-101-00, SP90M-101-00-20 and SP90M-101-00-50), the following item is added to the standard accessories.

Item	Part Number	Picture
7P Lemo-to-SAE power cable, 0.6 m	95715	

For part numbers including a UHF radio (SP90M-101-60, SP90M-101-60-20 and SP90M-101-60-50), the following items are added to the standard accessories.

Item	Part Number	Picture
Power/Data cable, 1.5 m, DB9-f to OS/7P/M to power jack	59044	
5" whip antenna (TNC) for 410-470 MHz radio	44085-60	



Country-Specific Power Cord

You should have ordered the power cord you need to power the AC/DC power supply, depending on the country where the receiver is to be used. The table below summarizes the different part numbers available for this item.

Item	Part Number	Country/Continent
Power cord, 1.8 m (6 ft) in length	105778-SPN	North America
	78656-SPN	Japan
	78653-SPN	Europe
	78654-SPN	UK
	101202-SPN	Taiwan
	102376-SPN	China
	78655-SPN	Australia

GNSS Antenna and Antenna Cables

The Spectra Precision offer in terms of GNSS antennas and coaxial cables that may be used with the SP90m is summarized in the table below.

Item	Part Number	Picture
"Spectra Precision SPGA Rover" antenna (can be used either as a rover or base antenna)	135000-00	
Coaxial, TNC/TNC, right angle, 1.6 m	58957-02-SPN	
Coaxial, TNC/TNC, right angle, 10 m	58957-10-SPN	

Pre-Installed Firmware Options

The list of pre-installed firmware options is given below. It applies to all available SP90m packout kits listed on *page 4*.

ID	Designation
N	GPS-SBAS-QZSS
G	GLONASS
O	GALILEO
B	BEIDOU
H	IRNSS
X	L1TRACKING
Y	L2TRACKING
Q	L5TRACKING
T	L6TRACKING
L	LBAND
W	20Hz
J	RTKROVER
K	RTKBASE
D	DUO
M	MODEM
U	WIFI
R	RECORD

Upgradable Firmware Options

These firmware options can be purchased separately to upgrade the receiver.

ID	Designation	Part Number
8	Fast Output (50 Hz)	113329-01
c	Embedded NTRIP Caster	113329-02
@1	Worldwide use (disables pre-installed Geofencing)	113329-03

	In order to use the Trimble RTX service Center-Point RTX, a subscription is required.. The result of the purchase will be a code that you will have to type in, in the same way as you would do to activate a firmware option in the receiver using the Web Server.	Visit Trimble RTX website to purchase a subscription.
--	---	---

NOTE: The result of a separate purchase is a POPN (Proof Of Purchase Number) emailed to the buyer. The POPN is then entered in the receiver using the *SP Loader* software utility (see *page 114*) to activate the purchased firmware option.

Other Optional Accessories

Other accessory kits (cables, antennas, radios) may be used with the SP90m. Please contact your distributor for more information.

Equipment Description

Front Panel

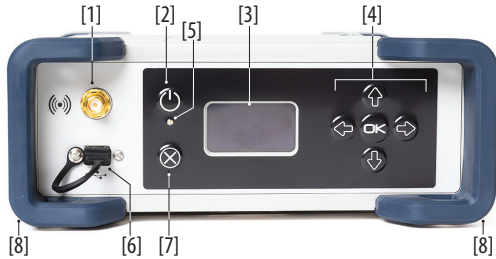

- **[1]:** External Bluetooth/WiFi antenna connector. A coaxial female connector (reverse SMA type) allowing you to connect a Bluetooth or WiFi antenna for wireless communication with a field terminal or any other device.
- **[2]: Power** button.



To turn on the receiver, press the Power button for about two seconds until the power LED **[5]** turns solid green, then release the button. The receiver will automatically complete its initialization phase before it starts operating normally.

To turn off the receiver, press the same Power button for about two seconds. The Power LED will blink green until the receiver gets turned off.

- **[3]:** Display screen. The display consists of a 128 x 64-pixel, 1.5-inch monochrome blue-gray OLED screen.







Used in conjunction with the direction keys, the **OK** and **Escape** keys, the display screen allows you to view and edit different pages of information. See *Receiver User Interface on page 26* for a detailed description of the information available from this screen.

After a few seconds of keypad inactivity, screen luminosity is turned off.

- **[4]:** Keypad including four direction keys and a central **OK** key. See details on *page 26*.



- [5]: Power LED. Possible states:

State		Meaning
	Off	SP90m is off and no external power source is connected to the DC power input (but the internal battery may be present).
	Solid green	SP90m is on (initializing or steady state), being powered from an external power source. If the internal battery is present, battery charging from the external source will take place if needed (see battery icon on General Status screen).
	Solid green, but with 0.5-s "off" time every 2 sec	SP90m is on (initializing or steady state), being powered from the internal battery. No external power source is applied.
	Blinking green	SP90m is running a 5-second power-off sequence following a long press on the Power button (regardless of the power source used).
	Solid red	SP90m is off and an external power source is connected to the receiver. The internal battery may be missing or present. If it is present, that means the battery is fully charged.
	Blinking red	SP90m is off and an external power source is connected to the receiver. An internal battery is present and being charged from the external power source.

- [6]: USB OTG mini connector (port U or M).

This is a five-contact connector. Depending on how it is configured, the USB port can be connected to:

1. A USB host, such as a USB key (mass storage device), using cable P/N 107535. **The receiver supports any FAT32-formatted key in USB 2.0 version, with 15 MBytes/second (or better) read speed. If these requirements are met, any size and model of USB key can be used.**
2. A USB device (port U), allowing USB serial communication using a standard USB cable (not provided).

This port is used typically for downloading/deleting files using *SP File Manager*, (in this case the receiver is seen as a disk) or upgrading firmware/warranty date using *SP Loader*.

The first time you connect the SP90m to a computer through a USB connection, the required driver will automatically be installed on the computer. If however the

installed driver does not work, you may replace it with one of the two drivers posted on the Spectra Precision website: http://www.spectraprecision.com/eng/sp90m.html#WUKG_NxLep0
 USB driver for 64-bit OS: SpectraPrecisionUSBSerialSetup_x64.exe file
 USB driver for 32-bit OS: SpectraPrecisionUSBSerialSetup_x86.exe file
 Double-click on the downloaded file to install the driver.



- [7]: **Escape** button. See *Using the Front Panel Controls* on page 26.
- [8]: Bumpers (x2).

Rear Panel

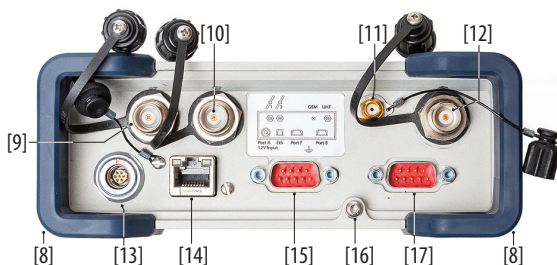

- [8]: Bumpers (x2).
- [9]: GNSS input #1. A TNC coaxial female connector allowing you to connect the first GNSS antenna to the receiver via a coaxial cable.
- [10]: GNSS input #2. A TNC coaxial female connector allowing you to connect the second GNSS antenna to the receiver via a coaxial cable.
- [11]: External GSM antenna (optional). A coaxial female connector (SMA type) allowing you to connect an external cellular antenna.

The SP90m having a built-in GSM antenna, no external GSM antenna is usually required. In case of adverse reception conditions however (e.g. SP90m mounted in a rack), an external antenna can advantageously be used for better reception. Run the Web Server (**Receiver> Network> Modem> Modem Antenna**) to choose which of the internal or external antenna should be used.

The SP90m uses a GSM antenna when it sends or receives RTK or differential corrections via its GSM modem.

- [12]: UHF radio connector. A TNC coaxial female connector allowing you to connect a radio whip antenna. This connector is available only if the SP90m has been fitted with an internal radio.

Warning! Do not confuse this coaxial connector with the GNSS inputs. Connecting a GNSS antenna to the UHF connector might damage it if the embedded UHF transmitter is used (however the transmitter will not be transmitting until there are enough GNSS satellites tracked and used).

- **[13]:** DC Power input and serial port A (RS232). A seven-contact, female connector allowing the SP90m to be powered from either the provided AC adapter (connect the cable extension between SP90m and the end of the AC adapter output cable), or an external 9- to 36-V DC power source through cable P/N 730477 (e.g. base setup using an external radio transmitter).
- **[14]:** Ethernet connector. A 7-contact female connector (RJ45) allowing you to connect the SP90m to a local network (LAN). Through this connection, you may remotely control and monitor SP90m operation from any computer connected to the Internet. Data may also flow through this connection, in the same way as through a serial port.
- **[15]:** RS232 serial port F, a SubD, nine-contact, male connector. The PPS signal and the not operational yet CAN bus are also available on this connector.
- **[16]:** Earth terminal. A screw terminal for connecting the receiver chassis to Earth.



Electric Isolation: All signals available on the following connectors are optically isolated from the receiver's internal circuitry and chassis ground, as well as from each other:

- Serial ports A, B and F (including DC power output voltage on port A)
- Ethernet port
- USB port
- **[17]:** Switchable RS232/RS422 serial data port B (default is RS232), a SubD, nine-contact, male connector. The External Event input is also present on this connector.

SIM Card

The SIM card slot is located under the battery. Open the battery compartment (see *page 13*) and then insert the SIM card as shown below. Gently push the card to the right until you hear a click.

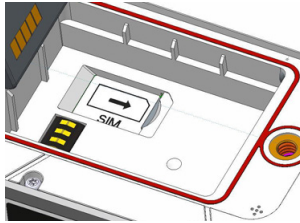

To extract the SIM card, gently push it a bit further in. This releases it from the slot. Just let go before extracting the SIM card from the battery compartment.

Battery Model & Battery Compartment

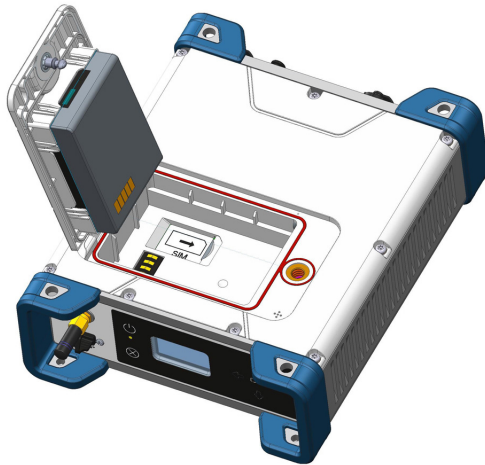

The battery used is a Lithium-Ion 7.4-V DC - 3700 mAh rechargeable battery. It is housed in a compartment accessible from above the SP90m.

The battery door can be opened by lifting and then turning the quarter-turn wing nut counter-clockwise.

The battery must first be inserted in the battery door (see picture) and then you can close and lock the battery door. The battery will smoothly connect to the receiver when closing the battery door.

The battery will automatically operate as a backup power source for the receiver if for some reason the external DC source used was removed from the DC power input.

Conversely, the battery will be charged by the external power source when needed. Indications are provided to report battery charging when this happens (see *page 9*).

NOTE: If you are using a SIM card, you must insert it before inserting the battery. (See *page 13*).

Buzzer The internal buzzer will sound whenever an error is detected. The buzzer will sound six times and then stop. The error icon will however continue to blink. To acknowledge the error notification, go back to the General Status screen (see *page 27*) and then press **OK**.

The buzzer can be deactivated permanently from the front panel screen. Go to **Display Settings**, then go down into the options until **Buzzer** is displayed. From there you can disable the buzzer. Refer to *page 36* as well.

Port Pinouts **USB Port**

On front panel, USB OTG “mini-B” connector.
5-C connector, fitted with sealing cap.



Pin	Signal Name
1	USB ID
2	GND
3	Device (D+)
4	Device (D-)
5	Host (VBus)

Power In, Serial Port A

On rear panel. A 7-C Connector.

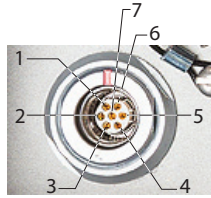

Pin	Signal Name	Description
1	GND-A	Ground for serial port (electrically isolated from chassis ground)
2	PWR IN -	Ground for power input (electrically isolated from chassis ground)
3	TXD (Output)	Port A RS232 TXD
4	RTS (Output)	Port A RS232 RTS
5	CTS (Input)	Port A RS232 CTS
6	PWR IN +	External Power Input (9-36 V DC)
7	RXD (Input)	Port A RS232 RXD

NOTE: All signals are electrically isolated from the chassis ground and power source.

Serial Port B

On rear panel. A switchable RS232/RS422 serial port + external event input.

A 9-C connector fitted with a sealing cap.



Pin	RS232	RS422
1	NC	NC
2	RX (IN)	RX+ (IN)
3	TX (OUT)	TX- (OUT)
4	NC	NC
5	GND-B	GND-B
6	NC	NC
7	RTS (OUT)	TX+ (OUT)
8	CTS (IN)	RX- (IN)
9	EVENT	EVENT (IN)

Port B can be switched to RS232 or RS422 using the \$PASHS,MDP command. RS232 inputs/outputs are typically ± 10 Volt asymmetrical signals with respect to ground. RS422 inputs/outputs are 0/+5 Volt symmetrical signals (differential lines).

NOTE: All signals are electrically isolated from the chassis ground and power source.

Serial Port F

On rear panel. A standard RS232 serial port + CAN bus + 1PPS output.

A 9-C connector fitted with a sealing cap.



Pin	Signal Name
1	CAN POWER (IN)
2	RX (IN)
3	TX (OUT)
4	CANH
5	GND-F
6	NC
7	CANL
8	NC
9	1PPS (OUT)

The 1PPS output is similar to a standard TTL output (0/+5 V):

- VOH Min= 4.5 V at IOH = + 4 mA
- VOL Max= 0.4 V at IOL= - 4 mA

NOTE: All signals are electrically isolated from the chassis ground and power source.

Ethernet Port

On rear panel.

An 8-pin RJ45 waterproof connector, fitted with sealing cap.

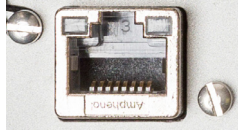

Pin	Signal Name
1	TX+
2	TX-
3	RX+
4	NC
5	NC
6	RX-
7	NC
8	NC

NOTE: All signals are electrically isolated from the chassis ground and power source.

Physical and Virtual Port IDs

Port ID	Port Definition
A	External serial port (RS232)
B	External serial port (RS232/RS422)
C, H	Bluetooth SPP (server)
D	Internal UHF radio
F	External serial port (RS232)
I, J	TCP/IP ports (server)
M	Internal or external memory, data recorded as G-file
P, Q	TCP/IP ports (client)
T	Bluetooth SPP (client)
U	USB external serial port

Installation Instructions

Receiver

NOTE: Depending on how you install the receiver, you may need to change the orientation of the displayed data on the front panel screen. This is possible using one of the options in the **Display Settings** menu (see *page 36*).

Tripod Mount

In land surveying applications, for example when used as a roaming base mounted on a tripod, the SP90m can be secured on one of the legs of the tripod using the lug ([A]) fastened on its bottom side (see illustration below).

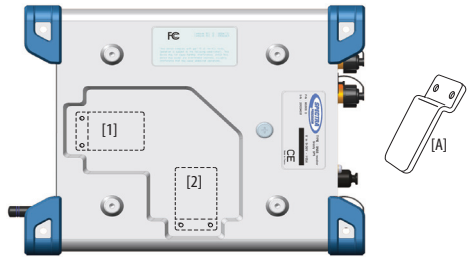

The lug may be secured onto the receiver case in two different ways allowing the receiver to be installed either with its front panel upwards ([1]) or sideways ([2]) (recommended).

Bottom Plane Mount

This type of installation is suitable for machine guidance or marine applications. The SP90m is secured from underneath the receiver case, using four screws M4.

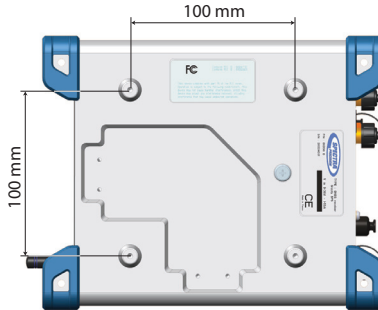

Preparing the support on which the receiver will be mounted only consists of drilling four holes, forming a simple,

100-mm square. In the receiver case, the four tapped holes are designed as follows: M4 x 0.7 - 7 mm. When tightening M4 screws, the recommended torque is 2.6 N.m (23 lbf.in). Note that this is a VESA¹-compliant mounting scheme.

Bumper Mount

This type of installation is also suitable for machine guidance or marine applications.

In this setup, the receiver is secured from its bottom side, using the holes (dia. 4.5 mm) located in the lower part of the four blue bumpers (see illustration below). The receiver will be secured using M4 screws of appropriate length inserted through these holes. Other holes (dia. 6.5 mm) also exist in the upper part of the bumpers so you can insert a screwdriver and tighten the four M4 fixing screws.

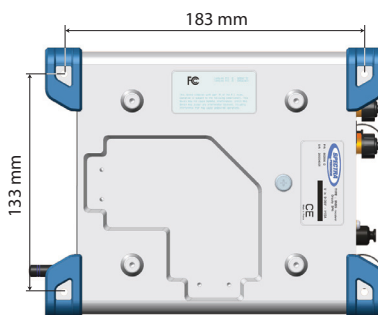

GNSS Antennas Setup for Heading Measurements

Choosing the Appropriate Baseline Length

In theory, the baseline length (i.e. the distance between the phase centers of the two GNSS antennas used, also called antenna separation) can be set between 5 centimeters and 1,000 meters.

In practice, you will choose the baseline length taking into account the level of expected heading accuracy as well as the various installation constraints in the vehicle.

The chart below shows the expected heading accuracy for a baseline ranging from 30 centimeters to 150 meters.

1.VESA= Video Electronics Standards Association.

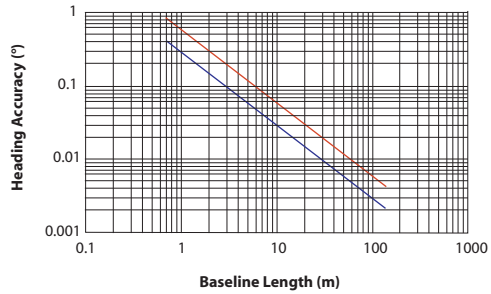

This chart deserves a few more comments and explanations:

- Accuracy is inversely proportional to baseline length. However a too long baseline can result in multipaths between antennas and introduction of vehicle flexing into the heading solution. These two factors are detrimental to heading accuracy. In addition, the longer the baseline, the longer the calibration sequence. That's why baselines of three to five meters are recommended. Baseline lengths less than one meter are not advised.
- Accuracy figures given above are 1-sigma values, or RMS, which means that 67% of the measurements are at or below these figures.
- Heading accuracy will be about a factor of 2 better than pitch or roll accuracy. Pitch and roll accuracies are the same.
- The lower line (blue) represents accuracy achievable if no multipath errors were present. In a normal environment, this is not possible. Multipath effects from typical environments are depicted by the upper line (red). For a given baseline length, the performance of the SP90m should lie somewhere near the upper line.
- A moving vehicle does not experience as many multipath effects as when it is stationary. This is because multipath is a correlated error. Correlated errors become more noise-like under vehicle dynamics and therefore can be filtered out. Therefore, accuracy results improve toward the lower line (blue) when the vehicle is moving.

Elevation Offset

Ideally, the two antennas should be installed at the same elevation. You may however be facing some installation constraints on your vehicle compelling you to install the antennas at different elevations. If that is the case, this is how you should calculate the elevation offset between the two

antennas after measuring the elevation deviation and the baseline length. The sign of the elevation offset is also provided on the diagram below (elevation offset negative if the secondary antenna is lower than the primary antenna and vice versa).

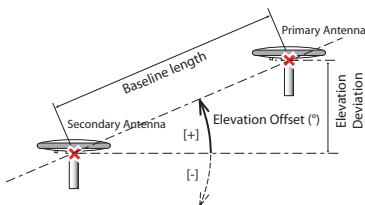

$$|Elevation\ Offset\ (^{\circ})| = \arcsin \frac{Elevation\ Deviation\ (m)}{Baseline\ Length\ (m)}$$



The elevation offset should not be more than 45 degrees (or less than -45 degrees), or the receiver will consider the antenna setup to be invalid. No heading, roll or pitch measurements would be calculated in this case.

Azimuth Offset

Ideally, the two antennas should be installed in such a way that the baseline direction is strictly parallel or perpendicular to the vehicle centerline.

However, you may also be facing some installation constraints on your vehicle compelling you to install the antennas differently. The azimuth offset describes the non-alignment of the baseline with respect to the vehicle centerline.

When the baseline is strictly parallel to the centerline and it is oriented in the direction of forward movement, the azimuth offset is zero. In all other cases, the offset is non-zero and should be measured as shown in the diagram below.

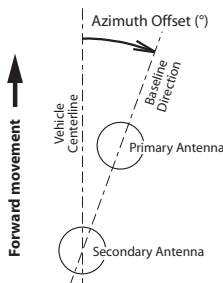

The non-alignment of the baseline with respect to the vehicle centerline may be intentional (see explanations in the next section below).

Azimuth Offset, Antenna Setup & Resulting Heading

Consider the following four setups before installing your antennas. This explanation applies to all types of vehicles (ship represented in our example).

Depending on the type of measurements you wish the receiver to perform (heading + roll or heading + pitch) and the installation possibilities offered aboard the vehicle, you will choose the most appropriate setup and set the azimuth offset accordingly.

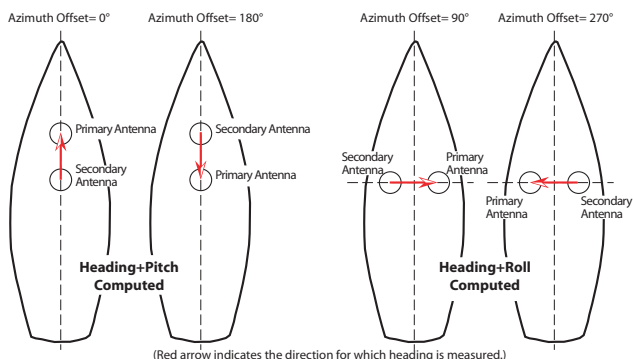

For each of these setups, if you enter the indicated azimuth offset, then the receiver will deliver the vehicle's true heading, and not the heading value it actually computes.

Delivering an RTK Position for the Primary Antenna

There may be an additional requirement you should take into account when setting up your antennas which is that the receiver should also deliver an RTK position for the primary antenna.

In this case, the absolute location of the primary antenna in the vehicle is probably critical and this will impact the location of the secondary antenna as well.

Powering the SP90m

External DC Source vs. Internal Battery

The SP90m may be powered from either its internal battery or an external DC source.

The internal battery will be charged if necessary when the receiver is powered from an external DC source.

Power Mode

You may set the receiver to behave in a very specific way when applying or removing the external DC source. Below are the options you may use and the resulting behavior. Note that these settings can only be done using the Web Server:

- With **Automatic Power-on** enabled, the receiver will be turned on automatically when an external DC source is detected at the DC power input, whether the internal battery is present or not.

With this option disabled, you will have to turn on the receiver manually after connecting the external DC source to the DC power input.

- With **Automatic Power-off** enabled, the receiver will be turned off automatically when the external DC source is removed from the DC power input, even if the internal battery is still present in the receiver at that time.

With this option disabled, and if the internal battery is present, you will have to turn off the receiver manually after disconnecting the external DC source from the DC power input.

To change the power mode settings, run the Web Server, go to **Receiver > Configuration > Power Mode** and set the displayed parameters as required.

Charging the Internal Battery

The battery comes with four LEDs indicating the current battery charge status. Push the button by the LEDs to read the battery charge status. All lit LEDs means the battery is fully charged. If none of them lights up when pushing the button, then the battery is exhausted and needs recharging. The battery may be charged in two different ways:

- Leave the battery within the receiver's battery compartment and charge it from the external DC source you are using to power the receiver. The charging state will be reported as an icon on the General Status screen (see *page 27*).
- You may use the dual-battery charger provided as part of the receiver shipment.

Before inserting the battery, insert a spacer in the battery slot used (see picture below where the two spacers provided have been inserted into the charger and the battery has then been inserted into one of them). Two battery spacers/inserts are provided with the receiver shipment.

Connect the charger to the power supply (provided), which you then connect to the power line.



Charging takes approximately 3 hours at room temperature. If two batteries are inserted in the battery charger, then the batteries will be charged sequentially, from left to right.

Warning: Ensure that nothing obstructs the vents in the back and bottom of the charger and that the charger is placed on a hard, flat and level surface, to ensure that there is airflow under the charger. Do not operate the battery charger while it is in the transport case.

On the charger, beside each slot are two LED indicators (red and green) to display the battery status.



Status	Red	Green
No battery detected (no battery present or battery defect)	On	Off
Battery detected (charging not started yet) - Conditioning not required - Conditioning required	Off Blinking	Off Off
Charging in progress - Conditioning not required - Conditioning required - Over/under temperature (charge is inhibited)	Off Blinking 1 flash / 25 s	Off Blinking Blinking
Conditioning in progress	On	Blinking
Conditioning done (battery fully charged)	On	On
Battery fully charged - Conditioning not required - Conditioning required	Off Blinking	On On
Power supply over/under voltage	Off	1 flash / 25 s

Using an External Battery

When used in the field as a roaming base, the SP90m may be powered from a standard car battery for example, provided you take these precautions:



- Connect the receiver to an external battery, using an SAE-terminated cable with electric wires all certified UL 758 and CSA C22.2 No. 210, or similar.
- The minimum wire section should be AWG 18.
- The cable should include a 5-A fuse placed in series. The fuse should be certified “UL listed” and CSA certified 3-30 A (or equivalent).

Receiver User Interface

The diagram below summarizes all the receiver parameters that you can display or edit from the receiver front panel. It also shows which keys to use to scroll through the different screens.

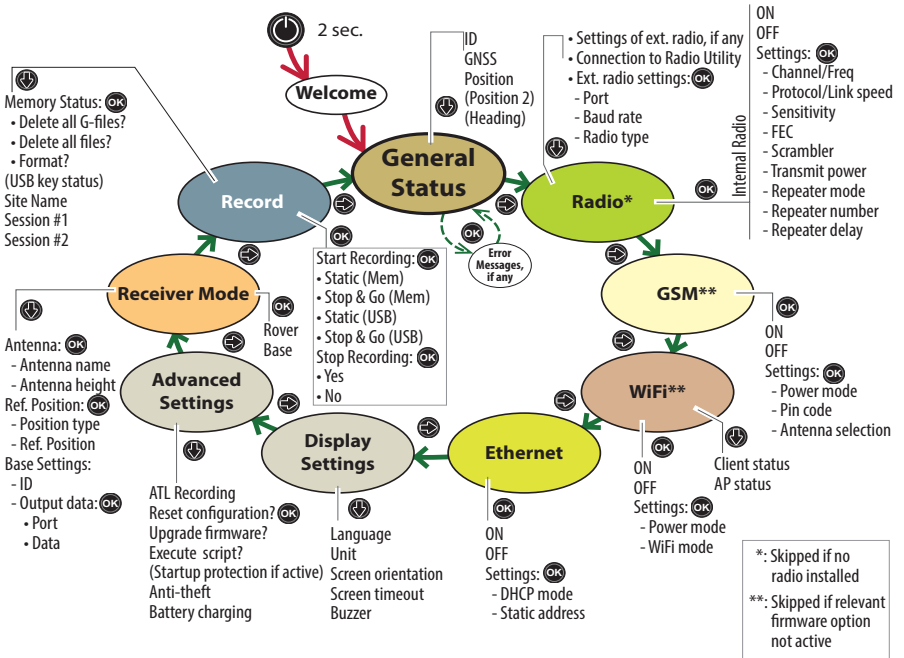

NOTE: You can navigate in the reverse order using the left-arrow button.

Welcome Screen





This screen appears after about 2 seconds of depressing the **Power** button. (You may then release this button.)

After about 10 to 20 seconds of displaying the Spectra Precision logo – corresponding to the receiver boot sequence – the screen will get blank for a few seconds, then the General Status screen will appear automatically.

Using the Front Panel Controls

- : Use the horizontal (left and right) arrow keys to scroll through the different screens. Horizontal arrows are also used to switch from a digit to another when you are editing a numerical value.

- : When a function title is displayed, use the vertical (up and down) arrow keys to scroll through the possible options, if any.
 Where **Settings** is displayed and after selecting it, use the vertical arrow keys to make a selection within a choice of possible parameters.
 Vertical arrows are also to be used when you are requested to enter numerical values, such as repeater delay or static IP address. In this case, use vertical arrows to set a value for each digit.
 In fields that combine letters and figures (password for example), a long press on either of these keys allows you to switch between lower-case, upper-case and numeric entry.
- : Use the **OK** button to enter the edit mode (for those functions that have one) or to validate a selected parameter.
- Where options are listed for you to choose, the currently active option is marked with a right arrow (▶).
- The General status screen has no associated edit mode but should error messages be reported, the **OK** button can then be used as acknowledgment. Press **OK** as many times as there are error messages to be acknowledged.
- Display Settings** and **Advanced settings** are access points to additional parameters. After you have selected one of them, just press one of the vertical keys to select an option in the menu. Then press the **OK** button to enter the edit mode for this parameter.
- : Use the **Escape** button to go up to the “parent” screen, when applicable. A long press on the **Escape** button will take you back from anywhere to the General Status screen (except if you are editing a value).







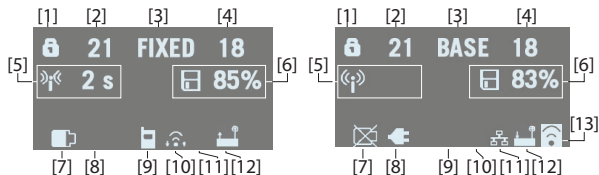







NOTICE: The screenshots illustrating this section are just examples. Your receiver may show different information depending on its own configuration.

















General Status

See examples below for a rover (left) and a base (right). Refer to the tables below for more details on each of the icons or data reported on this screen.



NOTE: In the second column, the slash symbol ("/") is used between icons to indicate that these icons occupy the area successively at the indicated displaying rate.

Area	Icon or Data Reported	Meaning
[1]		Anti-theft or/and startup protection active (solid icon).
		Receiver running after entering startup protection password. Startup protection still active and will require same password at next power up.
		One or more alarms set (blinking icon). Press the Scroll button as many times as necessary to read and acknowledge the alarms.
		One or more alarms set and anti-theft or/and startup protection active. Icons appear in succession every 1 second.
	(Blank)	No alarm set and anti-theft protection inactive.
[2]	{a number}	Total number of satellites from all GNSS constellations visible (tracked) from the current location.
[3]	{a text string}	Position solution status: – NONE: Position not available – AUTO: Autonomous GNSS position – DGPS: Differential GNSS position – SDGPS: SBAS Differential GNSS position – BDGPS: BeiDou only position solution – FLOAT: Float solution – FIXED: Fixed solution (RTK is operational) – RTX: CenterPoint® RTX solution – BASE: Receiver configured as a base.
[4]	{a number}	Total number of satellites actually used.
[5]	Data link information:	
	 {x seconds}	For a rover: Corrections received. The age of corrections is displayed after the icon, when available.
		For a base: Corrections generated and transmitted.
	(Blank)	No corrections received or transmitted.
[6]	Memory information and raw data recording:	
	 {percent}	No data recording in progress (static icon). Percentage of free memory in the storage medium used.
	 /  {percent}	Data recording in progress (dynamic icon). Percentage of free memory in the storage medium used. Icons appear in succession every 1 second.
	 / 	ATL data recording in progress
	 / 	Data recording through sessions in progress
[7]	Battery:	
	 / {percent}	A battery has been inserted in the compartment and the energy left in the battery is represented both visually and as a percentage. These two indications are shown successively (percentage appears for 1 second every 5 seconds).
		The battery is missing (battery compartment empty).

Area	Icon or Data Reported	Meaning
[8]		The receiver is powered from the AC/DC power supply, not from its battery.
[7], [8]		The battery is being charged from the external DC source (first icon is animated to show charging).
Modem:		
	(Blank)	Modem turned off.
[9]	 or 	Modem turned on: <ul style="list-style-type: none"> • Blinking: Not initialized yet • Static: Initialized and ready for a connection <p>The vertical bars indicate the signal strength at the modem antenna input. The higher the number of bars the better.</p> <p>The antenna symbol shown in the upper left corner stands for "2G". If the modem detects a 3G network, "3G" is displayed instead.</p>
		When the signal strength is very weak, four dots appear at the bottom of the icon, instead of vertical bars.
		Modem on line/connected to the cellular network.
WiFi:		
	(Blank)	WiFi turned off.
[10]		WiFi Client active (1 to 3 waves depending on signal level).(1 wave: no signal yet). (Blinking icon: WiFi Initializing.)
		Data being transmitted over WiFi (2 to 3 waves).
[11]		Ethernet connection active
		Data flowing through Ethernet connection
	(Blank)	No Ethernet connection
Bluetooth, Radio, USB:		
		Bluetooth connection active
		Internal radio connected, but not used
[12]		Internal radio used respectively as receiver, transmitter or repeater
		USB connection active
		Any combination of the five icons is possible. Icons appear in succession every 1 second.
	(Blank)	No Bluetooth or USB connection active, no internal radio installed.
WiFi (continued):		
[13]		WiFi Access Point active (Blinking icon: WiFi Initializing).

Use the down-arrow key to view the following pages of information:

1. **Receiver identification screen.** From top to bottom (see screen example):

- **SN:** Receiver serial number
- **FW:** Installed firmware version
- **WD:** Receiver warranty date (YYYY-MM-DD).
- **BT:** Receiver Bluetooth name. If the name does not entirely fit on the screen, it will automatically and slowly be scrolled from right to left.

```
SN: 5703A00111
FW: 3.50.5
WD: 2017-04-16
BT: SP90m_0301
```

2. **Constellations tracked/used:** Number of satellites tracked (used) from all possible eight constellations (see example: GPS, GLONASS, Galileo, BeiDou).

Press one of the horizontal arrow keys to display the status of the next four constellations: SBAS, QZSS, L-band, IRNSS.

```
GPS: 10(09) ►
GLONASS: 11(09)
Galileo: 03(02)
BeiDou: 03(00)
```

3. **Position solution:**

If the receiver is a rover, the displayed position will be the last computed position. The coordinates will be local (“LOC”) only if the rover receives specific RTCM messages from the base describing the local system used by the base.

If the receiver is a base, the displayed coordinates are set ones (not computed ones) representing the WGS84 or local reference position assigned to the base.

See screen example for a rover delivering WGS84 coordinates.

First line: Number of satellites tracked; Current position solution status; Number of satellites used.

Next three lines: Coordinates of receiver position. This may be:

- Either WGS84 coordinates (“W84” displayed at the beginning of the last line). Coordinates are Latitude (2nd line), Longitude (3rd line) and ellipsoidal height (4th line).
- Or local coordinates (“LOC” displayed at the beginning of the last line). Depending on whether or not a projection is defined in the local coordinate system used, coordinates may be either Easting (2nd line), Northing (3rd line), Elevation (4th line), or Latitude (2nd line), Longitude (3rd line) and Ellipsoidal Height (4th line).

```
17 FIXED 15
47° 17' 56.2926 N
001° 30' 32.5897 W
W84 +76.36 m
```

4. **Position solution 2:** Position of second antenna, if any second antenna connected to the receiver. Same information is provided as above for first position solution. When two position solutions are computed, there is a figure displayed in the top-left corner of the screen allowing you to know which position corresponds to which antenna:

- ①: Means the displayed position solution is that of the primary antenna (input #1).
- ②: Means the displayed position solution is that of the secondary antenna (input #2).

5. **Heading:**

- **First line:** Number of satellites received, computation status and number of satellites used.

Computation status:

- NONE: Check that the two antennas are connected.
- CALIB: Calibration is in progress, no valid heading value is available yet.
- FLOAT: Integer ambiguities are being solved, no valid heading value is available yet.
- FIXED: Heading computation is now effective.

- **Second line:** Computed value of heading
- **Third line:** Computed value of pitch
- **Fourth line:** Computed value of roll

The SP90m can deliver either pitch or roll, not both at the same time.

Radio

When you access the Radio screen, the following information is displayed:

- **First line:**
 - Receiver port that the radio is connected to: A, B or F= external radio; D= internal radio
 - Radio function: “Rx” for receiver, “Tx” for transmitter
 - Radio model
 - Current power status: ON or OFF
- **Second line:** Channel number used and its corresponding frequency, in MHz.
- **Third line:** Protocol used and transmission speed (baud rate).

```
31 FIXED 21
Heading: 121.5°
Pitch: ---
Roll: 2.3°
```

(Rover)

```
D Rx XDL ON
2 420.2500 MHz
TFST 19200 Bd
LOW FEC SCR 4FSK
```

(Base)

```
D Tx XDL ON
2 420.2500 MHz
TFST 19200 Bd
2W FEC SCR 4FSK
```

```
Radio
▶ ON
OFF
Settings
```

• **Fourth line** (see examples on the left):

- For a rover, current reception sensitivity (low, medium or high), followed by “FEC” (Forward Error Correction) and “SCR” (Scrambling) if these two functions are enabled, followed by the type of modulation used and “REP” if the radio is used as a repeater.
- For a base, radiated power (500 mW, 1 W or 2 W), followed by “FEC” (Forward Error Correction) and “SCR” (Scrambling) if these two functions are enabled, followed by the type of modulation used.

If the fourth line does not fit on the screen, it will be automatically scrolled from right to left.

The Radio screen being displayed, press the **OK** button to enter the edit mode. From there, you can turn on or off the internal radio.

If you highlight the third option (**Settings**) and press **OK**, you can edit each of the following radio parameters. After setting a parameter, press **OK** to save it and then press the down-arrow button to access the next parameter:

- **Channel/Freq:** Depending on how the radio was set up, you can choose a channel and corresponding frequency from a list of preset channel/frequency choices.
- **Protocol/Linkspeed:** Possible choices are:

25 kHz Channeling	12.5 kHz Channeling
TTALK@4800	TRANS@4800
TTALK@9600	TRANS@9600
TTALK@16000	TMARK@4800
SATEL@19200	TTALK@4800
TT450S@4800	TTALK@8000
TT450S@9600	SATEL@9600
TMARK3@19200	TT450S@4800
TFST@19200	TMARK3@9600
TRANS@4800	TFST@9600
TRANS@9600	ULINK@4800
TRANS@19200	
TMARK@4800	

- **Sensitivity** (Low, Medium or High)
- **FEC** (ON or OFF)
- **Scrambler** (ON or OFF)
- **Transmit power** when the radio is used as a transmitter (500 mW or 2 W).
- **Repeater mode** (ON or OFF)

- **Repeater number** (Base/1 repeater, Base/2 repeaters, Repeater one, Repeater two)
- **Repeater delay** (in ms).

Still from the Radio screen, pressing any of the vertical keys will first display the settings of the external radio, if any, then a message (**Connect Internal Radio to ADLCONF?**) prompting you to connect the internal radio to a configuration utility program (ADLCONF):

- If you press **OK**, a new message will be displayed asking you to confirm this. If you press **OK** again, the internal radio will be made accessible directly from port A on the receiver rear panel.

From there, if you connect a computer to port A and you run ADLCONF on the computer, you will be able to configure the radio directly from ADLCONF.

When you are done with the radio configuration, you will need to turn off the receiver and then turn it back on to restore normal operation for the internal radio.

- If you press the down arrow, a new screen will be displayed allowing you to access the settings of the external radio, if there is one connected to the receiver. If you then press **OK**, you can change the following parameters:
 - **Radio Port:** ID of the port (A, B or F) on receiver side used to connect the external radio to the receiver. Once you have chosen a port and pressed **OK**, you can then access the two parameters below.
 - **Baud Rate:** Data speed used on the serial line connecting the external radio to the receiver.
 - **Radio Type:** Model of external radio used (ADL, PDL, XDL)

GSM

When you access the GSM screen, the following information is displayed:

- **First line:** Current modem status (OFF, ONLINE, READY, DIALING or ON)
- **Second line:** Alternately identification of the service provider (ISP) and SIM card phone number.
- **Third line:** Network type (2G or 3G) and measured signal level (in 20% increments; 100%: +43 dBm)
- **Fourth line:** Type of currently active connection (NTRIP or Direct IP) followed by mount point name (in NTRIP), or

```
GSM ON
Orange F
3G: 40%
NTRIP: PSTRF2
```

server address, i.e. host name or IP address (in Direct IP).
Blank if no active connection.

The GSM screen being displayed, press the **OK** button to enter the edit mode. From there, you can turn on or off the GSM modem.

NOTE: Turning on the GSM may take up to 4-5 minutes.

If you highlight the third option (**Settings**) and press **OK**, you can edit each of the following GSM parameters. After setting a parameter, press **OK** to save it and then press the down-arrow button to access the next parameter:

- **Power Mode: Manual or Automatic.** “Automatic” means the GSM module will be powered on when you turn on the receiver. “Manual” means you turn it on or off manually from the GSM screen.
- **PIN code:** Press **OK** to enter the edit mode.
CAUTION: You won't be able to turn on the GSM modem until you have entered the correct PIN code.
- **Antenna Selection:** Press **OK** to choose the antenna used by the GSM modem: This can be the built-in antenna (Internal) or an external antenna connected to the rear panel (see [11] on *Rear Panel on page 11*).

WiFi

When you access the WiFi screen, the following information is displayed (see examples on the left, first in Access Point mode and second, in client mode):

- **First line:**
 - “WiFi” label
 - WiFi mode: “AP” (for Access Point) or “Client”. “AP” is similar to “Hotspot WiFi”
- **Second line:** Receiver's WiFi name (WiFi SSID), as seen from an external WiFi device in search of a new connection. In client mode, this line displays the SSID of the WiFi device the receiver is connected to.
- **Third line:**
 - In Access Point mode: Receiver's static IP address
 - In Client mode: Connection status: “Connected” (or “Not connected” if the second line is empty).
 - Signal level (in 20% increments; 100%: +43 dBm)
- **Fourth line:** (client mode only): IP address of WiFi hotspot the receiver is connected to.



GSM
ON
▶ OFF
Settings



WiFi AP ON
SP90m_030111
192.168.130.1



WiFi Client ON
IP: 45.145.2.14
Connected



The WiFi screen being displayed, press the **OK** button to enter the edit mode. From there, you can turn on or off the WiFi device.

If you highlight the third option (**Settings**) and press **OK**, you can edit each of the following parameters. After setting a parameter, press **OK** to save it and then press the down-arrow button to access the next parameter:

- **Power Mode: Manual or Automatic.** “Automatic” means the WiFi module will be powered on when you turn on the receiver. “Manual” means you turn it on or off manually from the WiFi screen.
- **WiFi Mode: Client, Access Point or AP and Client.**
In **Client** mode, the receiver’s WiFi module is set to search for a nearby WiFi network. You need to use the Web Server to find and connect to a WiFi network.
In **Access Point** mode, the receiver’s WiFi module may be used by nearby, external, WiFi-enabled equipment (a smart phone for example) as a WiFi hotspot.
In **AP and Client** mode, the WiFi device may be used simultaneously as a client or an access point.

NOTE: When it is powered on from the dedicated display screen (see above), the WiFi device is automatically set as a WiFi Access Point.

IMPORTANT: The receiver’s default WiFi key is the receiver’s serial number.

Ethernet

When you access the Ethernet screen, the following information is displayed (see example on the left):



- **First line:** Ethernet status (ON or OFF)
- **Second line:** DHCP state (ON or OFF)
- **Third line:** Receiver IP address (if DHCP off) or 4 x 3 hyphens if DHCP on.

The Ethernet screen being displayed, press the **OK** button to enter the edit mode. From there, you can turn on or off the Ethernet device.

If you highlight the third option (**Settings**) and press **OK**, you can edit each of the following parameters. After setting a parameter, press **OK** to save it and then press the down-arrow button to access the next parameter:



- **DHCP Mode:** If set to ON, the interrogated DHCP server will assign a dynamic IP address to the receiver.

If it's OFF, use the following field to define an IP address for the receiver.

- **Static Address:** IP address assigned to the receiver when DHCP is off. This is a static IP address (up to 12 figures in the form xxx.xxx.xxx.xxx).

To enter a new IP address, press **OK** then use the vertical arrow keys to set each digit, and the right-arrow key to move to the next digit.

Display Settings

This screen looks like this:



Pressing the down-arrow button will allow you to set the following parameters, one after the other:

1. **Language:** Choose the user interface language (several western languages available).
2. **Unit:** Choose the distance unit (**Meters**, **US Survey Feet**, **International Feet**).
3. **Screen Orientation:** Choose the orientation of the data displayed on the screen (**Normal** or **Upside down**).
4. **Screen timeout:** Choose the time in minutes during which the screen will stay lit after you leave the control panel inactive. It will go blank after this delay. You will then need to press any front panel button to turn it back on. Enter "0000" to keep the screen permanently on.
5. **Buzzer:** Allows you to silence the buzzer if required. The buzzer is on by default.

Advanced Settings

This screen looks like this:

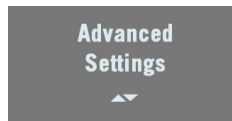

Pressing the down-arrow button will allow you to set the following parameters, one after the other:

1. **ATL Recording:** Is OFF by default. ATL data are used for advanced diagnosis. You don't normally have to record ATL data unless you are requested to do so by Technical Support.

When you activate ATL recording, the screen looks like this:



ATL ON
Memory
ATL_17306_142935.log
00:03:26 896 KB

Then make a long press on **Escape** to return to the General Status screen so you can freely use the other screens.

To stop ATL recording, go back to the ATL Recording screen and press **OK**. Press **OK** again as a positive answer to the message "**Stop ATL?**". ATL recording stops right away.

2. **Reset configuration?:** This screen allows you to reset the receiver. You need to confirm this request before the reset actually takes place.

During a reset, all parameters are reset to their defaults, except for ephemeris, almanac, position and time data. SBAS ephemeris data are however cleared. Then the default_config.cmd file is run if present.

"**RESET IN PROGRESS**" is displayed throughout the sequence (which may take a few minutes). At the end of the sequence, hold the **Escape** button depressed for a few seconds to return to the General Status screen.

3. **Upgrade firmware?:** Allows you to upgrade the firmware of your receiver.

When Spectra Precision releases a new firmware version, copy the corresponding *.tar file to a USB key then connect the key to the receiver via the USB connector on the receiver front panel.

Once done and after selecting the **Upgrade firmware?** function, the screen will show the firmware version you can now install. Press **OK** if you agree and let the receiver complete the installation. For more information on firmware upgrades, see *page 45* or web page **Receiver > Configuration > Firmware Upgrade** in the Web Server.

4. **Execute script?:** Allows you to have the receiver executing all the proprietary commands listed in the *.cmd file stored on the connected USB key.
5. **Startup Protection Active:** This screen is visible only if the startup protection has been activated through the Web Server. It is visible under the **Advanced Settings** screen but will also pop up whenever you want to enter the edit mode for any of the receiver parameters.

When this screen is visible, you are prompted to unlock the receiver (“**Unlock receiver?**” displayed). Just press **OK**, enter the password and press **OK** again to make the receiver fully operational.

When the startup protection is active, the receiver does not display or/and output its results of position computation.

6. **Anti-Theft:** This screen allows you to enable or disable the anti-theft protection. You need to enter the correct password if you want to remove the anti-theft protection.
7. **Bat. Charging:** Use this option to enable or disable the charging of the internal battery from an external DC source, when present at the power input. This option is enabled by default. Turning battery charging off may be useful when the external power source used is also a battery and you want to save energy from this battery.

Receiver Mode See flowchart and explanations below.

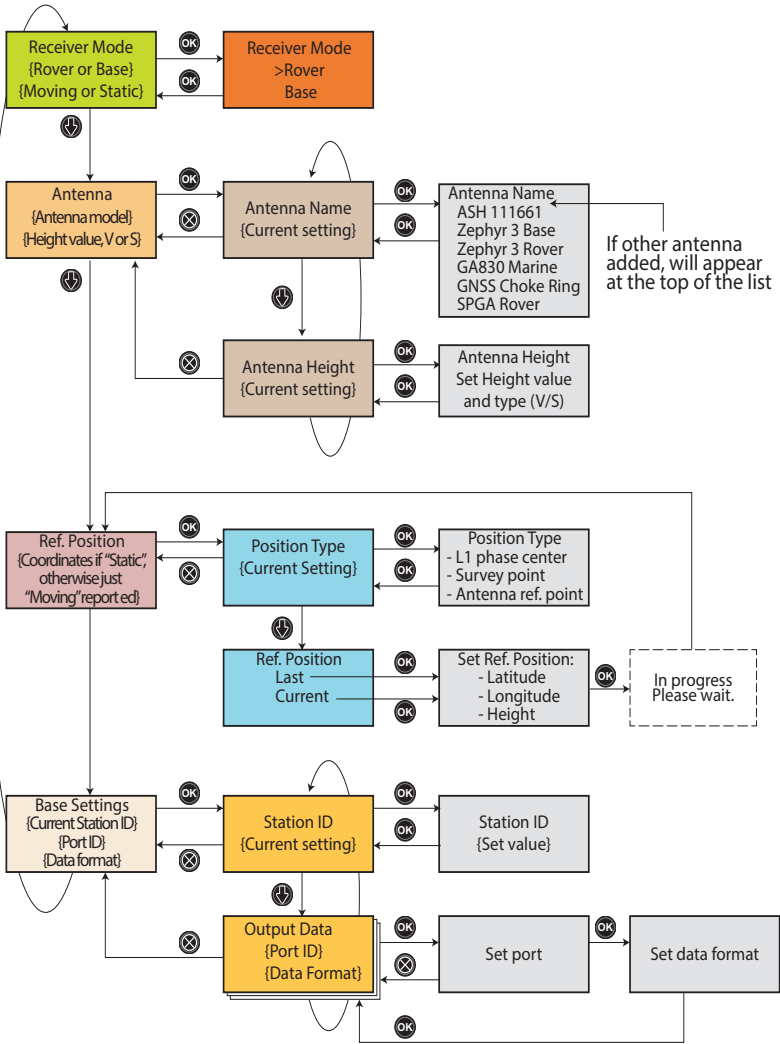

Receiver Mode
Base
Static

When you access the Receiver Mode screen, the following information is displayed:

- **Receiver Mode** status: Current receiver operating mode. It can currently be used as a base or a rover.
- **Ref. Position**: The type of position currently defining the base location. The base may be "Moving" or "Static" ("Static" being the result of selecting either "Current" or

“Last” as the reference position. See **Ref Position** below for more details).

IMPORTANT: Using the receiver front panel, you can only configure a static base, not a moving one. Defining a moving base can only be done using the Web Server. However, after a receiver reset, if you turn the receiver into a base from the front panel, then the base will operate by default as a moving base.

The Receiver Mode screen being displayed, press the **OK** button to enter the edit mode. From there, you can choose to define the receiver as a base or a rover

The Receiver Mode screen being still displayed, press the down-arrow key to access the following parameters:

- **Antenna:** This screen lists the model and height of the antenna currently used (see example).

Second line: Antenna model

Third line: Antenna height and corresponding type of height measurement (“V” for Vertical or “S” for Slant).

Press **OK** to edit these parameters. The following is displayed, one after the other:

- **Antenna Name:** Press **OK** again to select the model of antenna used. A list of antennas commonly used with the receiver is provided.

Choose one, press **OK**, then press the down-arrow key to switch to the next parameter below.

- **Antenna Height:** Press **OK** again to set the antenna height. The antenna height results either from a vertical height measurement (select “V” after entering the measured value) or from a slant height measurement (select “S” after entering the measured value).

Press **OK** when you are done, then press **Escape** to return to the Antenna screen, then the down-arrow key to switch to the next parameter (see below).

- **Ref. Position:** If the base was last defined as moving, then the screen only shows the “**Moving**” status. If the base was last defined as static, the screen shows the position currently defined as the base’s reference position (see example).

Second line: Latitude of reference position

Third line: Longitude of reference position

Fourth line: Height, preceded by an acronym identifying the point used as vertical reference (this may be **PC1** for

Antenna
Zephyr 3 Base
02.000 m V

Ref. Position
47°31'30.00005"N
001°04'49.00000"W
ARP +0058.90 m

“L1 Phase center”, **SPT** for “Survey Point” or **ARP** for “Antenna Reference Point”).

Press **OK** to edit these parameters. The following is displayed, one after the other:

- **Position Type:** Press **OK** again to choose the vertical reference. As explained, this may be the antenna phase center (**L1 phase center**), the antenna phase center point projected to the ground (**Survey point**) or the base plane of the antenna (**Antenna ref. point**).

Press **OK** once you have made your selection, then press the down-arrow key to switch to the next parameter below.

- **Ref. Position:** Choose the way you want to define the base position. This can be the last known reference position or the current position computed by the receiver. When you make one of these choices, the receiver returns the corresponding position, which you may possibly modify before validating it.

When you select **Current** or **Last** and no computed position is available at this time, or no position has been computed since you turned on the receiver, then blank fields will be shown and you will have to type in the reference position by yourself.

Press **OK** once this step is complete, then press the down-arrow key to switch to the next parameter below.

- **Base Settings:** This screen provides information on the base settings:

Second line: Base ID

Third and fourth lines: Port delivering data and type of data output (see example). If several outputs are defined, the third and fourth lines show successively the definition of each of these outputs.

- **ID:** A four-figure number (0000 to 9999). Choose an ID in line with the chosen data format (possible formats listed below).
- **Port:** The possible choices are: **A Serial**, **B Serial**, **C Bluetooth**, **D XDL**, **F Serial**, **H Bluetooth**, **I TCP 8888**, **J TCP 8889**, **P NTRIP IP**, **Q NTRIP IP**, **U USB Serial**.
- **Data:** The possible choices are: **OFF**, **ATOM 4**, **ATOM 100**, **ATOM 101**, **RTCM-2.3**, **RTCM-3.0**, **RTCM3.2**, **CMR**, **CMR+**.

Press **OK** precisely at the time a given port and data format are displayed so you can edit these parameters:

- First set the port and press **OK**



Ref. Position
Last
Current

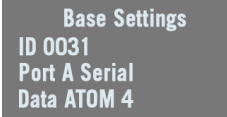

Base Settings
ID 0031
Port A Serial
Data ATOM 4

- Set the data format then press **OK**.

Raw Data Recording

When you access the Record screen, the following information is displayed:

- Status: ON or OFF
- Storage medium: Memory or USB key

The Record screen being displayed, press the **OK** button to enter the edit mode. From there, you can choose to start a Static or Stop & Go data recording. See flowchart below.

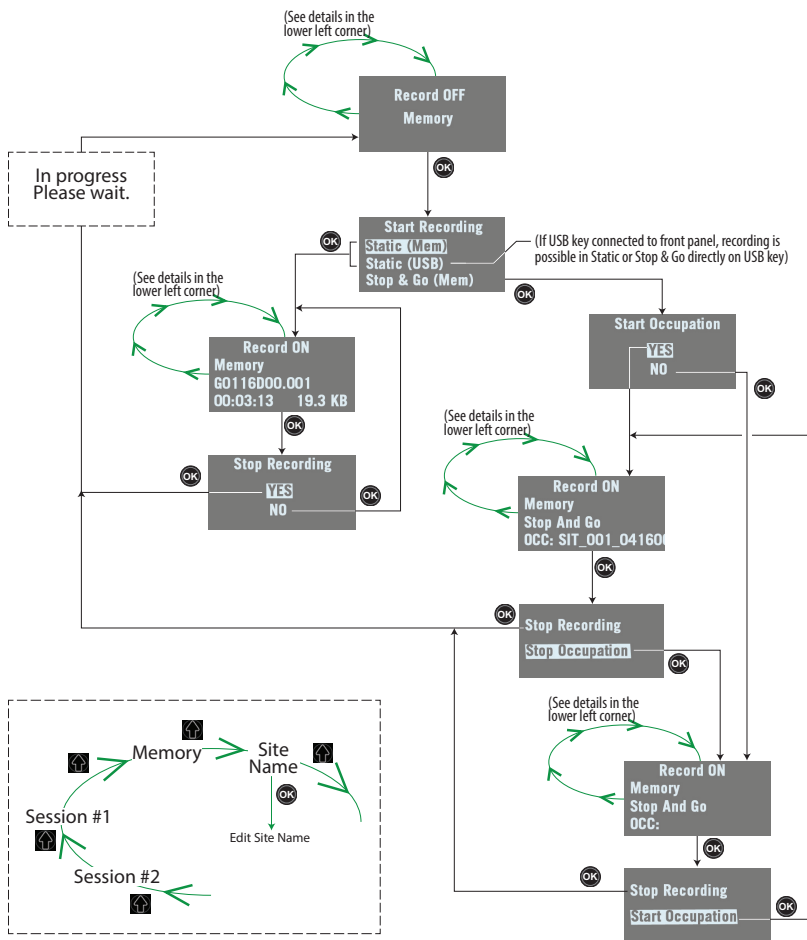

The Record screen being displayed, press the down-arrow key to access the following parameters:

- **Memory:** Describes the memory used (memory size, amount of free space, number of G-files stored in the memory).

If you press **OK**, you access a new menu from which you can delete files from the memory, or format the memory:

- **Delete all G-Files?**
- **Delete all files?**
- **Format?**

Whatever the choice you make in this menu, you will have to confirm it before the corresponding action actually takes place.

- **Site Name:** Enter a name for the location where data recording will take place.
- **Session #1:** Press **OK** to access the sessions menu. This menu allows you to enable (**ON**) or disable (**OFF**) the execution of sessions batch #1.

Once you have enabled the sessions batch, the menu offers an additional choice: **Stop <Session ID>** to suspend the running session, or if the session has already been suspended, **Start <Session ID>** to resume data recording within this session.

When session batch #1 is running, the screen then shows:

- 2nd line: **ON** status followed by the ID of the running session.
- 3rd line: **Recording** displayed, meaning raw data are being recorded.
- 4th line: Start time and end time of the running session.

If you enable session batch #1 and there has been no session programmed in the batch, or there is no session in the batch that coincides with the current time, then the screen will display the following:

- 2nd line: **ON** status
- 3rd line: **No Session** displayed
- 4th line: Blank.

- **Session #2:** same as session #1.

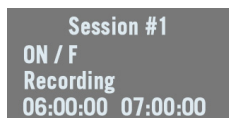

Session #1
ON / F
Recording
06:00:00 07:00:00

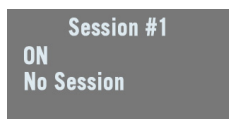

Session #1
ON
No Session

Power-Off Screen

Hold down the **Power** button for a few seconds. The Spectra Precision logo will appear on the screen.



After a few seconds, the message “**Powering off...**” will follow, indicating that the receiver is being turned off.

If the anti-theft protection is still enabled when you ask for receiver power-off, a message will ask you to confirm your request.



If you wish to keep using the anti-theft protection, press **OK** and then the receiver will complete the power-off sequence as described above.

If you want to remove the anti-theft protection before turning off the receiver, press **Escape**, go back to **Advanced Settings** to remove the anti-theft protection (see *page 36*). Then you can turn off the receiver as explained above.

Using a USB Key



To Copy Files

Whenever you connect a USB key to the receiver via cable P/N107535, the following screen is displayed:



This screen is displayed for a few seconds. If you press **OK** while this screen is still displayed, all the G-files and log files stored in the receiver will be copied to the root folder on the USB key (or will overwrite the files with same name). Otherwise the copy operation will be skipped and the receiver will come back to the General Status screen. The screen looks like this while the files are being copied.



The same will happen if you power on the receiver with a USB key already connected to the receiver.

To Upgrade the Firmware

When a new firmware upgrade is available, it is easy to install the new firmware using a USB key.

- Use your computer to copy the installation file (a *.tar file) to the root directory of the USB key.
- The receiver being turned off, connect the USB key to the receiver through cable P/N 107535 (provided).
- Press the **OK** button and the **Power** button simultaneously for a few seconds. This starts the upgrade.

The screen will read successively:

{Spectra Precision logo}
USB Upload
Upgrading Firmware Step 1/5
Upgrading Firmware Step 2/5
Upgrading Firmware Step 3/5
Upgrading Firmware Step 4/5
Upgrading Firmware Step 5/5
Upgrading Firmware Complete
{Booting: Spectra Precision logo}
{Regular receiver startup to General Status screen}

Let the receiver proceed with the upgrade. **Do not turn off the receiver while the upgrade is in progress.**

NOTE: If there is no USB key connected or the key does not contain any firmware upgrade file, then the process will abort after a few seconds.

Because data has to be decompressed on the USB key during an upgrade, the USB key must be unlocked, with at least 100 MBytes of free memory, before starting the upgrade. The upgrade will fail if there is not enough free space on the key.

Getting Started With the Web Server

Introduction to the Web Server

Description and Function

The Web Server is a receiver-embedded, HTML-based firmware application, designed to enable the receiver owner (the “administrator”) to monitor and control the SP90m GNSS receiver through a TCP/IP connection.

Running the Web Server for the First Time

As the receiver owner, after establishing a TCP/IP connection between your computer and the receiver (via its Ethernet port or via WiFi; see *page 53* and *page 48*), do the following:

- Run a web browser on your computer.
- Type the IP address (or host name) of the receiver in the web browser, then press the Enter key (see *page 52*).

This will launch the Web Server in the receiver, which in turn will open a web page in the web browser.

Depending on how the Web Server has been configured, you may be asked to log in. The first time you launch the Web Server, use the default connection profile (the “administrator profile”) to log in. This profile is the following:

- Username: **admin**
- Password: **password**

You can customize the administrator profile by changing the username and password. The Web Server will let you do this from its **Security** page (see on-line Help file attached to this page).

Security

The receiver owner may restrict the access to the Web Server by implementing one of the three possible security levels described below, sorted from the highest to the lowest security level:

1. **Enabled:** On launching the Web Server, the user is requested to log in by entering a username and password. After having logged in, the user has full control over the receiver (operation monitoring, access to configuration). As the administrator, you may decide to share the administrator profile (username and password) with other trustworthy users. You may also create new connection profiles for some other authorized users using \$PASH commands.

Remember that registered users have exactly the same rights as the administrator, including managing users through \$PASH commands.

2. **Enabled with Anonymous Access:** Anyone who has been given the IP address or host name of the receiver has direct access to the Web Server (no log-in required). Only receiver monitoring is allowed in this case. An anonymous user CANNOT change the receiver configuration.

After the Web Server has been launched with this level of security, the administrator, or any other authorized user, can log in on the **Security** page (see on-line Help attached to this web page).

3. **Disabled:** No security is implemented with this option. Anyone who has been given the IP address or host name of the receiver has direct access to the Web Server, both for monitoring the receiver or changing its configuration. With this low protection level, the receiver owner will be well-advised to keep the receiver IP address or host name as confidential as possible.

WiFi-Based TCP/IP Connection

Setting Up the WiFi Device

- If the WiFi device has been turned off, it first needs to be turned back on:
 - On the receiver front panel, press one of the horizontal keys until you see the WiFi screen.
 - Press **OK**.
 - Select **ON**:



- Press **OK** again. After a few seconds the screen displays “WiFi ... ON”.

- Then you should indicate how the WiFi device will be power-controlled and whether it will operate as a WiFi client, as WiFi access point or both. Follow the steps below:
 - The previous screen being still displayed, press **OK**.
 - Select **Settings**:



- Press **OK** again.
- Choose a power mode for the WiFi device: press **OK**, select either **Manual** or **Automatic** (see explanations on *page 34* before making a choice) and then press **OK**.
- Press any of the vertical keys and then press **OK**.
- Choose an operating mode for the WiFi device: select either **Client**, **Access Point** or **AP and Client**, depending on the use case (see the next three sections below) and then press **OK**.
- On your laptop or smart phone, start searching for WiFi devices. When your SP90m receiver has been found, select it and then enter the WiFi key (by default the receiver serial number) to allow a WiFi connection with the receiver.
- Back on receiver side, press  to go back to the WiFi “root” screen. If you have selected **Access Point** or **AP and Client**, you will be able to read the IP address of the WiFi access point in the lower line. Type in this IP address (fixed, static address: 192.168.130.1) in your computer or smart phone’s web browser to launch the receiver’s Web Server.

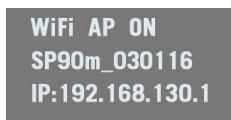

When a WiFi connection is active, one or two of the following icons appear on the General Status screen:



The first one indicates that the WiFi device is used as an access point and the second one as a client.

Using the WiFi Device as Access Point

Use the receiver's WiFi device as access point in the following cases:

- You want to access the Web Server from any WiFi-capable device such as a computer or a mobile device (e.g. smart phone).
- You are located within WiFi range of the SP90m.



Using the WiFi Device as Client

Use the receiver's WiFi device as client in the following cases:

- You want a remote access to the Web Server and Internet is easily accessible from the location where you are.
- The SP90m is operated in a location where only a local WiFi network is available.

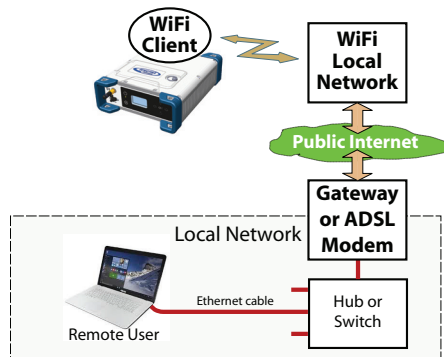

To select a WiFi network, you have to run the Web Server:

- Go to **Receiver > Network > WiFi**
- Unless already done, turn on the WiFi device, select the client mode and click **Configure**.
- Scan for WiFi networks, select one and then connect to it. The WiFi screen on the receiver should look as shown.

WiFi Client ON
WiFi Network Name
60% Connected
172.16.12.204

Using the WiFi Device as both Access Point and Client

Use the receiver's WiFi device as both access point and client in the following cases:

- You want to access the Web Server from your computer or smart phone.
- The SP90m is configured to receive or transmit corrections over the Internet via WiFi.
- You are located within WiFi range of the SP90m.

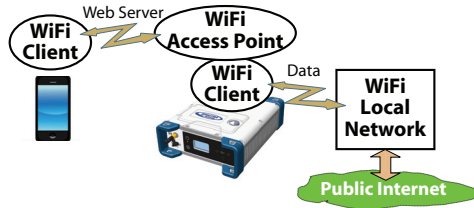

In this use case, the Web Server will be run from the smart phone via the receiver's WiFi device used as access point, whereas corrections will be routed over the Internet using the receiver's WiFi device as client.

Ethernet-Based TCP/IP Connection

In this use case, you will have to use a standard Ethernet cable (fitted with an RJ45 connector at either end) to connect the receiver to the local network.

To make this connection successful, you may have to take advice from your IT expert, depending on the local IP network environment. You should inform this person of the following before proceeding:

- The SP90m is not fitted –and cannot be fitted– with a firewall. If a firewall is needed in your local network, it should be installed on a device other than the SP90m.
- HTTP port #80 is used by default in the receiver to access the Web Server.

The choice of using the DHCP mode or not within the local network is also the decision and responsibility of the IT expert.

Typically, there are two possible cases of TCP/IP connection:

- TCP/IP connection within a local network.
- TCP/IP connection through the public Internet.

These are detailed in the sections below.

NOTE: It is assumed that the reader knows how to send \$PASH commands to the receiver.

Setting Up the Ethernet Device

- If the Ethernet device has been turned off, you first need to turn it back on:
 - On the receiver front panel, press one of the horizontal keys until you see the Ethernet screen.
 - Press **OK**.
 - Select **ON**:



- Press **OK** again. After a few seconds the screen displays “Ethernet ON”.
- Then you should indicate whether the receiver will be assigned a static IP address (DHCP off) or a dynamic IP address (DHCP on). If you don't know which option to use, ask your local IT expert. Follow the steps below:
 - The previous screen being still displayed, press **OK**.
 - Select **Settings**:



- Press **OK** again.
 - Choose the desired option and then press **OK**.
 - If you chose **DHCP Mode: ON**, there is nothing else to be done.

If you chose **DHCP Mode: OFF**, press one of the vertical arrows to access the **Static Address** screen. Press **OK** and then enter successively each of the figures making up the static IP address. Press **OK** when you are done.

When the IP connection is active, the icon below appears on the General Status screen:



NOTE: If you activate DHCP and there is no DHCP server in your network responding to the request, a static IP address (of the type 169.254.1.x) will be automatically assigned to the receiver (and displayed on the Ethernet screen). This is the IP address you should choose to connect to.

TCP/IP Connection Within a Local Network

In this use case, the receiver and the computer are connected to the same local area network (LAN) and may even be in the same room. Here the communication will not take place through the public Internet, but simply within the local network.

The connection diagram typically is the following.

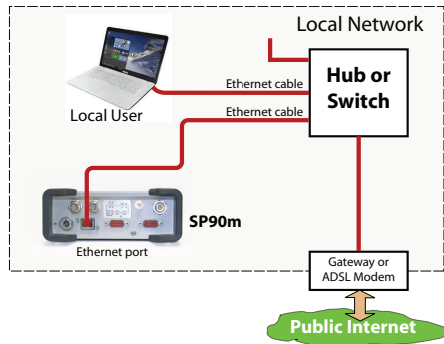

The valid receiver IP address is **the one shown in the lower line on the Ethernet screen.**

Example indicating the IP address to use with DHCP On:

```
Ethernet ON
DHCP ON
IP:10.20.4.30
```

TCP/IP Connection Through the Public Internet

In this use case, the receiver and computer are connected to different local networks. Here the communication will necessarily take place through the public Internet.

The connection diagram typically is as follows.

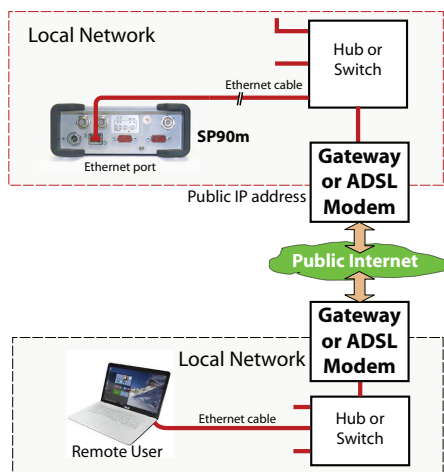

In this configuration, the IT expert should take all the necessary steps for the receiver owner to be able to access the SP90m through the public IP address of the local network. **In this case, the IP address shown on the receiver display screen is NOT the one to be entered in the web browser.**

It is therefore the responsibility of the IT expert to provide the appropriate connection information:

<IP address:port number> or host name

Introduction to Multi-Operating Mode

The SP90m is a multi-application GNSS receiver, making it possible to use different operating modes simultaneously.

The limitation to that feature is very simple to understand:

The maximum number of baselines the SP90m can calculate simultaneously is 3. The capability for the SP90m to support several operating modes simultaneously is simply derived from that statement.

NOTE: Working in a Trimble RTX mode does not “consume” a baseline, which means that the above statement would be more accurate if we said, “The maximum number of baselines the SP90m can calculate simultaneously is 3 + RTX”.

The consequences of this rule are as follows:

- In single-antenna configuration:
 - In Hot Standby RTK, you can configure the receiver to use up to three independent correction sources (= three baselines), thus making it possible to have up to two different backup position solutions available in case the first source of position solution fails.
 - In Hot Standby RTK + Relative RTK, you can only set two independent correction sources (= two baselines), to have a backup position solution available in case the first source of position solution fails. The third baseline is dedicated to the Relative RTK mode.
- In a two-antenna configuration, the heading mode may be combined with all of the existing rover modes:
 - Autonomous
 - RTK
 - Hot Standby RTK
 - RTK + Relative RTK
 - Only Relative RTK
 - Dual RTK
 - Dual Relative RTK

However, in Hot Standby RTK, there can only be two independent sets of corrections used (not three because one baseline is dedicated to computing heading).

Besides, the rover and moving base modes can be run simultaneously. To make this work, you should first configure the receiver as a rover, then as a moving base (and not the other way round). That way, while base corrections will be generated and delivered via your programmed output messages, the receiver will continue to compute RTK positions for its own location provided the required external corrections continue to enter the receiver.

Using SP90m With a Single Antenna

The reader is supposed to know how to run the Web Server (see *Getting Started With the Web Server on page 47*) and how to use the receiver user interface (see *Receiver User Interface on page 26*) before reading this section.

Remember, when using the Web Server, at any time you can access context-sensitive help by pressing this key:



Specifying the Model of Antenna Used

When using one single GNSS antenna connected to SP90m, only GNSS input #1 can be used. GNSS input #2 must not be used in a single GNSS antenna setup.

The setting described below is required prior to configuring the receiver in any of the operating modes described in the following sections.

Use the Web Server to specify the model of antenna connected to GNSS input #1:

- Go to **Receiver > Position > Sensors/Antennas Setup**.
- Set **Multi-Sensor Mode** to **Single Antenna**.
- Choose the point on the antenna for which you want the SP90m to compute the position (L1 phase center, ARP or ground mark).
- Describe the model and height of antenna used as the primary antenna:
 - Manufacturer
 - Antenna name and its RINEX name.
 - Method used to measure the antenna height (i.e. choice of the point on the antenna from which the height measurement is performed).
 - Value of measured distance according to the chosen antenna height measurement method.

NOTE: Entering the height makes sense if you want to get the position of the ground mark or if you enter the ground mark coordinates as a base's reference position.

- Keep the secondary antenna defined as UNKNOWN.
- Press **Configure**. The antenna model is now set.

NOTE: When configuring a static base from the receiver front panel, you will be able to select the model of antenna used (for the primary antenna). By default, if you leave the base mode to operate the receiver as a rover, the receiver will assume this antenna model is still used in the rover configuration.

Raw Data Recording



On the receiver's General Status screen, the following icons will appear in succession at a rate of 1 second when the receiver is actually collecting raw data:



Using the Web Server

Using the Web Server to launch data recording is particularly suitable for remote-controlled, static raw data collection.

- Go to **Receiver > Memory**.
- Enable **Data Recording**.
- Enter a site name for the location occupied by the receiver.
- Choose the memory where to save the raw data file.
- Choose a recording interval in Hz. Additionally, you may ask the receiver to record the "TTT" message resulting from the advent of any incoming external event and/or the "PTT" message providing the time-tagging of the PPS signal.
- Click **Configure**. The receiver starts recording the default messages programmed on port M (as listed after **Data type**). To change the content of this message, refer to *Raw Data Recording on page 78*).

In the right part of the **Memory** tab screen, at the bottom of the list of files stored in the selected memory, you can now see – shown in red – the name of the file being created.

Working from the Receiver Front Panel

Working from the receiver front panel to launch data recording allows a rover operator to choose between "**Static**" or "**Stop & Go**" data collection. A USB key connected to the receiver front panel may be used to save the raw data file once created.

- Press one of the horizontal keys until you see the "**Record OFF**" screen.

- Press **OK**.
- Choose the option that suits your requirements in terms of data collection type (Static or Stop & Go), the storage location (Mem or USB) used to save the file, then press **OK**.

This starts the data recording. Refer to *Raw Data Recording on page 42* to learn more about the workflow used.

Autonomous or SDGPS (SBAS) Rover

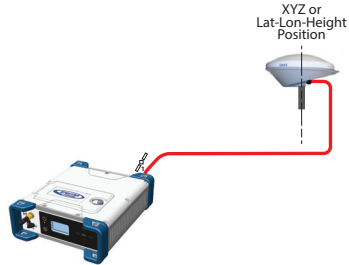



On the receiver's General Status screen, the receiver will display "AUTO" or "SDGPS" when computing a position respectively in autonomous or SDGPS mode. The computed position is displayed after pressing .

Use the Web Server to configure the receiver:

- Go to **Receiver > Position > Rover Setup**
- Set **Processing Mode** to **Autonomous**
- Additionally, in the **Other Settings** section, you may change the primary GNSS system used (**GPS** is the default selection), limit the level of position accuracy to **SBAS Differential Position** or **Standalone Position**.
- Select the model of dynamics that suits the movement pattern of your rover best.
- Click **Configure**. The receiver starts operating in autonomous mode. If SBAS satellites are received, the receiver will be able to deliver positions with SBAS Differential accuracy (provided SBAS is enabled; see **Receiver > Satellites**).

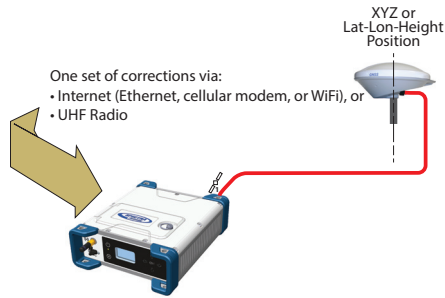
RTK or DGPS Rover



On the receiver's General Status screen, the receiver will display "FIXED" (with short "FLOAT" transition time) or "DGPS" when computing a position respectively in RTK or DGPS mode. The computed position is displayed after pressing .

When corrections are received and used,  is displayed on the General Status screen together with the age of corrections (see *General Status on page 27*).

To configure the receiver as a DGPS or RTK rover, use the Web Server as follows:

- Go to **Receiver > Position > Rover Setup**.
- Set **Processing Mode** to **RTK**.
- Specify how the corrections are forwarded to the receiver by setting **Input Mode** accordingly. If you choose **Automatic**, the receiver will find by itself which of its ports is used to acquire corrections. If you choose **Manual**, you need to specify this port.
- Additionally, in the **Other Settings** section, you may change the primary GNSS system used (**GPS** is the default selection), limit the level of position accuracy to less than what the receiver can actually achieve in this case. Typically you will choose **RTK Position** or **(RTCM) Differential Position** to match with the selected operating mode (respectively RTK or DGPS).
- Select the model of dynamics that suits the movement pattern of your rover best.
- Click **Configure**.
- Set the device used by the receiver to acquire corrections:
 - If corrections are received via radio, go to **Receiver > Radio** to enter all radio parameters. You may use the internal radio or an external radio.

- If corrections are received over the Internet, go to **Receiver > Network** to set the device used (this may be Ethernet, Modem or WiFi; more information about how to set up these devices can be found in the relevant context-sensitive Help). Then go to **Receiver > I/Os** to start data reception in NTRIP or Direct IP mode.

Hot Standby RTK Rover

Hot Standby RTK is similar to RTK except that two or three independent sets of corrections are used instead of one. The receiver will choose the best of the two or three sets of corrections received in order to improve position availability and accuracy.

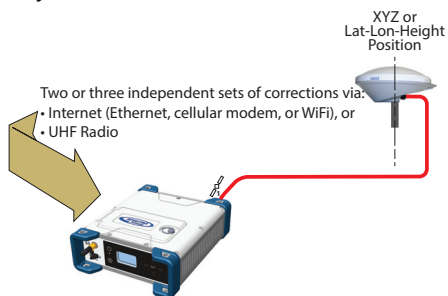

On the receiver's General Status screen, the receiver will display "FIXED" (with short "FLOAT" transition time) when computing a position in Hot Standby RTK mode. The computed position is displayed after pressing .

When at least one set of corrections is received and used,  is displayed on the General Status screen together with the age of corrections (see *General Status* on page 27). The displayed age of corrections is always that of the corrections actually used in the position computation.

To configure the receiver as a Hot Standby RTK rover, use the Web Server as follows:

- Go to **Receiver > Position > Rover Setup**.
- Set **Processing Mode** to **Hot Standby RTK**.
- Specify how the two (or three) sets of corrections are being forwarded to the receiver by setting **Input Mode** accordingly. If you choose **Automatic**, the receiver will find by itself which of its ports are used to acquire the sets of corrections. If you choose **Manual**, you need to specify each of the ports used.
- Additionally, in the **Other Settings** section, you may change the primary GNSS system used (**GPS** is the default

selection), limit the level of position accuracy to less than what the receiver can actually achieve in this case.

Typically you will choose **RTK Position** to match with the selected operating mode.

- Select the model of dynamics that suits the movement pattern of your rover best.
- Click **Configure**.
- Set the device used by the receiver to acquire the two or three sets of corrections:
 - If corrections are received via radio, go to **Receiver > Radio** to enter all radio parameters. You may use the internal radio or an external radio.
 - If corrections are received over the Internet, go to **Receiver > Network** to set the device used (this may be Ethernet, Modem or WiFi; more information about how to set up these devices can be found in the relevant context-sensitive Help). Then go to **Receiver > I/Os** to start data reception in NTRIP or Direct IP mode.

Trimble RTX Rover

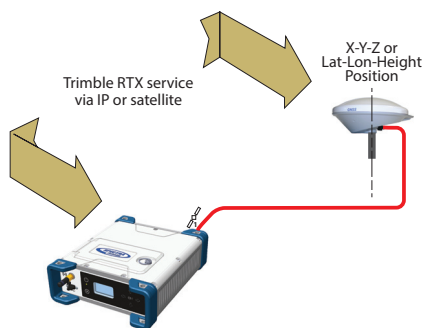

Using a Trimble RTX service in the SP90m requires that you first buy a subscription to this service. On the other hand, the receiver is ready to operate in Trimble RTX mode (dedicated firmware option has been pre-installed at the factory) provided an L-band capable GNSS antenna is used.

On the receiver's General Status screen, the receiver will display "RTX" when computing a position using a Trimble RTX service. The computed position is displayed after pressing .

To configure the receiver in RTX, use the Web Server as follows:

- Go to **Receiver > Position > Rover Setup**.
- Choose the channel through which RTX corrections enter the receiver by setting **Corrections Source** accordingly:
 - If you choose **Automatic**, the receiver will find by itself which channel to use (**L-Band** or **NTRIP**).
 - If you choose **L-Band**, the receiver will expect RTX corrections to come from a satellite.
 - If you choose **NTRIP**, the receiver will expect RTX corrections to come from the Internet.

NOTE: RTX corrections will come from the Internet only after you have taken all the steps to implement an active IP connection, either via GSM, WiFi or Ethernet. The connection to the remote RTX service will then be automatic.

- Set **Engine Mode** to **ON**.
- Select the datum and plate in which to deliver the coordinates of the computed position:
 - If you select **OFF**, the position will be expressed in the ITRF2014 datum.
 - If you select **ON**, choose a datum and a tectonic plate.
- Additionally, in the **Other Settings** section, you may change the primary GNSS system used (**GPS** is the default selection), limit the level of position accuracy to less than what the receiver can actually achieve in this case. Typically you will choose **PPP Position** to match with RTX.
- Select the model of dynamics that suits the movement pattern of your rover best.
- Click **Configure**.

WARNING: The way you set **Processing Mode** is very important here. If for example it is set to RTX and every step has been taken to have RTX corrections available (see *page 59*), then the receiver will automatically choose between RTX and RTK depending on which of these two modes is providing the best position solution. You will be able to know which mode is currently used by taking a look at the receiver's General Status screen.

RTK + Relative RTK Rover

Reminder: Relative RTK refers to the ability of the SP90m to compute and deliver the three components of the vector connecting a mobile base to this receiver. The components of the vector are provided with centimeter accuracy, just as is the position of the SP90m, as computed in RTK using corrections received from a static base.

One of the typical applications of Relative RTK is the constant monitoring of the position of a vessel relative to that of another vessel or to the jib of a crane used on a quay.

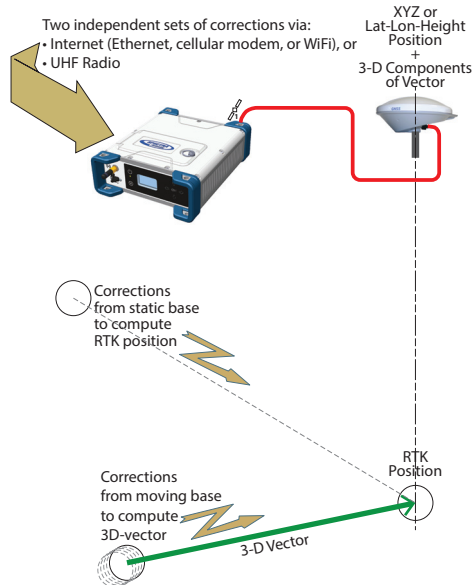

On the receiver's General Status screen, the receiver will display "FIXED" (with short "FLOAT" transition time) when computing a position in RTK mode. The computed RTK position is displayed after pressing . A new press on this button will display the computed components of the vector.

When at least one set of corrections is received and used, is displayed on the General Status screen together with the age of corrections (see *General Status on page 27*).

To configure the receiver in RTK+Relative RTK, use the Web Server as follows:

- Go to **Receiver > Position > Rover Setup**.
- Set **Processing Mode** to **RTK + Relative RTK**.
- Specify how the two sets of corrections are being forwarded to the receiver by setting **Input Mode** accordingly.

If you choose **Automatic**, the receiver will find by itself which of its ports are used to acquire the two sets of corrections.

If you choose **Manual**, you need to specify these two ports. The “**BRV**” line defines the port routing the corrections from a moving base allowing vector computation whereas the “**RTK**” line defines the port routing the corrections from a static base allowing position computation.

- Additionally, in the **Other Settings** section, you may change the primary GNSS system used (**GPS** is the default selection), limit the level of position accuracy to less than what the receiver can actually achieve in this case. Typically you will choose **RTK Position** to match with the selected operating mode.
- Select the model of dynamics that suits the movement pattern of your rover best.
- Click **Configure**.
- Set the device used by the receiver to acquire the two sets of corrections:
 - If corrections are received via radio, go to **Receiver > Radio** to enter all radio parameters. You may use the internal radio or an external radio.
 - If corrections are received over the Internet, go to **Receiver > Network** to set the device used (this may be Ethernet, Modem or WiFi; more information about how to set up these devices can be found in the relevant context-sensitive Help). Then go to **Receiver > I/Os** to start data reception in NTRIP or Direct IP mode.

Hot Standby RTK+ Relative RTK

This mode is similar to RTK+Relative RTK (see *page 63*) except that the RTK position is now a “Hot Standby RTK” one (see also *page 60*). The combination of these two modes may be summarized as shown in the diagram below.

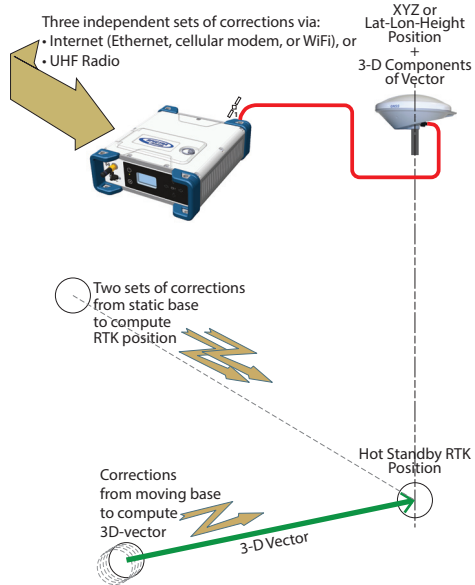

On the receiver’s General Status screen, the receiver will display “FIXED” (with short “FLOAT” transition time) when computing a position in Hot Standby RTK mode. The computed position is displayed after pressing .

When at least one set of corrections is received and used,  is displayed on the General Status screen together with the age of corrections (see *General Status on page 27*). The displayed age of corrections is always that of the corrections actually used in the position computation.

The components of the vector are visible in the Web Server (in **Receiver > Position > Vectors** tab on the right) or by programming an NMEA VCR or VCT message on one of the receiver ports (see Web Server’s **I/Os** tab).

To configure the receiver in Hot Standby RTK + Relative RTK, use the Web Server as follows:

- Make sure the Heading mode is off.
- Go to **Receiver > Position > Rover Setup**.
- Set **Processing Mode** to **Hot Standby RTK + Relative RTK**.
- Specify how the three sets of corrections are being forwarded to the receiver by setting **Input Mode** accordingly.

If you choose **Automatic**, the receiver will find by itself which of its ports are used to acquire the three sets of corrections.

If you choose **Manual**, you need to specify these three ports. The “**BRV**” line defines the port routing the corrections from a moving base allowing vector computation, whereas the “**Standby RTK**” lines define the ports routing the corrections (from one or two static bases), allowing position computation.

- Additionally, in the **Other Settings** section, you may change the primary GNSS system used (**GPS** is the default selection), limit the level of position accuracy to less than what the receiver can actually achieve in this case. Typically you will choose **RTK Position** to match to the selected operating mode.
- Select the model of dynamics that suits the movement pattern of your rover best.
- Click **Configure**.
- Set the device used by the receiver to acquire the three sets of corrections:
 - If corrections are received via radio, go to **Receiver > Radio** to enter all radio parameters. You may use the internal radio or an external radio.
 - If corrections are received over the Internet, go to **Receiver > Network** to set the device used (this may be Ethernet, Modem or WiFi; more information about how to set up these devices can be found in the relevant context-sensitive Help). Then go to **Receiver > I/Os** to start data reception in NTRIP or Direct IP mode.

Relative RTK Rover

Reminder: Relative RTK refers to the ability for the SP90m to compute and deliver the three components of the vector connecting it to a mobile base. The components of the vector are provided with centimeter accuracy.

One of the typical applications of Relative RTK is the constant monitoring of the position of a vessel relative to that of another vessel or to the jib of a crane on a quay.

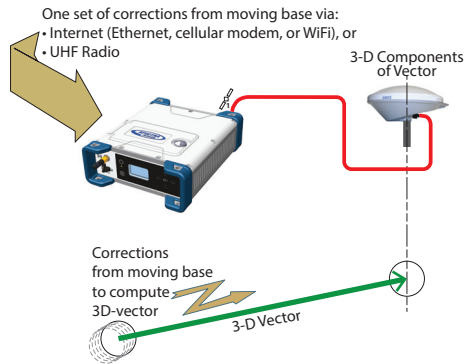

On the receiver's General Status screen, the receiver will display "AUTO" or "SDGPS" when computing a position in standalone or SBAS mode. The computed position is displayed after pressing .

The components of the vector are visible in the Web Server (in **Receiver > Position > Vectors** tab on the right) or by programming an NMEA VCR or VCT message on one of the receiver ports (see Web Server's **I/Os** tab).

When corrections are received and used,  is displayed on the General Status screen together with the age of corrections (see *General Status on page 27*).

To configure the receiver in Relative RTK, use the Web Server as follows:

- Go to **Receiver > Position > Rover Setup**.
- Set **Processing Mode** to **Only Relative RTK**.
- Specify how the corrections are being forwarded to the receiver by setting **Input Mode** accordingly. If you choose **Automatic**, the receiver will find by itself which of its ports are used to acquire the corrections. If you choose **Manual**, you need to specify the port.
- Additionally, in the **Other Settings** section, you may change the primary GNSS system used (**GPS** is the default selection) or change the **Output Position Type** field. Be

aware the position computed in Relative RTK, in terms of accuracy, is an SBAS Differential position at best.

- Select the model of dynamics that suits the movement pattern of your rover best.
- Click **Configure**.
- Set the device used by the receiver to acquire the two sets of corrections:
 - If corrections are received via radio, go to **Receiver > Radio** to enter all the radio parameters. You may use the internal radio or an external radio.
 - If corrections are received over the Internet, go to **Receiver > Network** to set the device used (this may be Ethernet, Modem or WiFi; more information about how to set up these devices can be found in the relevant context-sensitive Help). Then go to **Receiver > I/Os** to start data reception in NTRIP or Direct IP mode.

Static or Moving Base

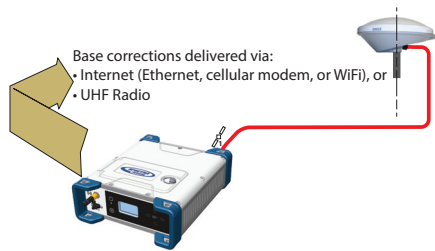

Using the Web Server

To configure the receiver as a base, use the Web Server as follows:

- Go to **Receiver > Position > Base Setup**.
- Use the **Station ID**. field to enter the identification number. Remember, the station ID should comply with the type of correction data format the base generates. As a reminder, this is the list of authorized numbers in relation to the data format used:
 - RTCM 2.3: 0-1023
 - CMR/CMR+: 0-31
 - ATOM & RTCM3.x: 0-4095
- Indicate whether the base is stationary (**Static**) or in motion (**Moving**).

If you choose **Static**, you need to specify the exact location of the base. You can do this in two different ways:

- Type in the three geographical coordinates (**Latitude, Longitude, Height**) of the base, as well as the location on the antenna (**Reference Position**) for which these coordinates are given.
- Or click on the **Get Current Position** button to make the currently computed position the new base position. In this case, it is assumed that the receiver actually calculates a position at the time you click the button. As a result, the above three coordinates fields above are overwritten with the current computed position, and the **Reference Position** field is automatically set to “**L1 Phase Center**”.

NOTE: The antenna height was entered when specifying the number of antennas used by the receiver (see *page 56*).

- Additionally, in the **Other Settings** section, you may change the primary GNSS system used (**GPS** is the default selection).
- Click **Configure**.
- Set the device used by the receiver to send out its corrections:
 - If corrections are broadcast via radio, go to **Receiver > Radio** to enter all radio parameters. You may use the internal radio or an external radio.
 - If corrections are broadcast over the Internet, go to **Receiver > Network** to set the device used (this may be Ethernet, Modem or WiFi; more information about how to set up these devices can be found in the relevant context-sensitive Help).
- You still have to set which corrections the base will generate. This is detailed in *Base Data Messages on page 77*.

NOTE: You may also set a base to use a virtual antenna. This is required when a rover using the corrections from this base has no information on the model of GNSS antenna used at the base. In this case a virtual antenna can be used (ADNULLANTENNA or GPPNULLANTENNA). If you don't need a virtual antenna, just keep the **Antenna Name** field set to **OFF**.

Working from the Receiver Front Panel

The receiver user interface offers an alternative to the Web Server to set up a static base. Please follow the detailed procedure described in *Receiver Mode on page 39*).

Using SP90m With Two Antennas

The reader is supposed to know how to run the Web Server (see *Getting Started With the Web Server on page 47*), and how to use the receiver user interface (see *Receiver User Interface on page 26*) before reading this section.

Remember, when using the Web Server, at any time you can access context-sensitive help by pressing this key:



Specifying the Models of Antennas Used

When using SP90m with two GNSS antennas, both GNSS input #1 and GNSS input #2 are used.

The setting described below is required prior to configuring the receiver in any of the operating modes described in the sections that follow.

Use the Web Server to specify the models of antennas connected to input #1 and input #2:

- Go to **Receiver > Position > Sensors/Antennas Setup**.
- Set **Multi-Sensor Mode** to **Two Antennas** or **Two Antennas (L1 only on input#2)** depending on the reception capability of the model of antenna you connect to input #2.
- Choose the point on the antenna for which you want the SP90m to compute the position (L1 phase center, ARP or ground mark).
- For each of the two antennas (primary and secondary antennas), describe the model and height of antenna used:
 - Manufacturer
 - Antenna name and its RINEX name
 - Method used to measure the antenna height (i.e. choice of the point on the antenna from which the height measurement is performed)
 - Value of measured height according to the chosen antenna measurement method.

NOTE 1: Entering the height only makes sense if you want to get the position of the ground mark.

NOTE 2: Antenna heights are not required when computing heading.

- Press **Configure**. The two antenna models are now set.

NOTE: When configuring a static base from the front panel, you will be able to select the antenna model used for the

primary antenna. By default, if you leave the base mode to operate the receiver as a rover, the receiver will assume this antenna model is still used as the primary antenna. You cannot choose an antenna model for the secondary antenna using the front panel. This operation needs to be done from within the Web Server.

SP90m Delivering Heading Measurements

The receiver will measure the heading angle of the vector connecting the secondary antenna to the primary antenna.

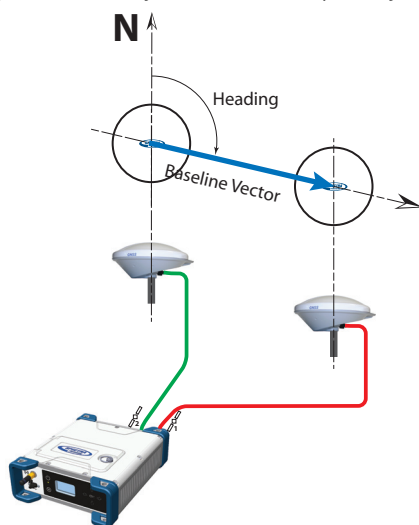

On the receiver's General Status screen, the receiver will display "AUTO" or "SDGPS" indicating that the position for the primary antenna is either computed in autonomous or SDGPS mode respectively.

Press one of the vertical keys to see the computed position for the primary antenna (marked ①) and the heading screen. No position is computed for the secondary antenna (marked ②).

Use the Web Server to configure the receiver:

- Go to **Receiver > Position > Heading Setup**
- Set **Mode** to **Heading**. This automatically sets **Input** to **Internal**.
- Use the **Length Type** field to qualify the baseline, i.e. the distance between the primary and secondary antennas:
 - If it is assumed to have a strictly fixed value (the two antennas are mounted on a single, rigid support),

select **Fixed**. After choosing this option, you may set the receiver to auto-calibrate the heading computation. In this case keep the **Auto-Calibration** option enabled. Or you may prefer to disable this option, in which case you will have to type in the exact length of the baseline, in meters (in the **Vector Length** field).

- If you think it may slightly vary over time (due to support deformation, presence of wind, etc.), select **Changing (Flex)**. If you choose this option, no auto-calibration is required.
- Enter the possible two offsets in relation to your antennas installation (see *GNSS Antennas Setup for Heading Measurements on page 19*) as well as the maximum expected vertical angle (**Max. Baseline Elevation**) the baseline may present compared to the horizontal, and the permitted tolerance on the baseline length (**Baseline Tolerance**).
- Click **Configure**. The receiver starts operating in heading mode.

Dual-RTK Rover

The SP90m may be configured to provide two RTK positions, one per antenna. These results can subsequently be used to compute the heading angle resulting from the orientation of the two antennas, while providing an accurate position for each of these two antennas.

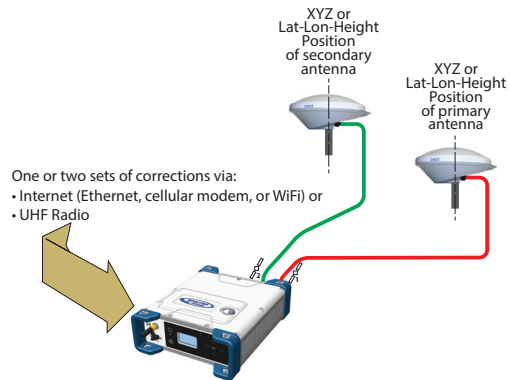

On the receiver's General Status screen, the receiver will display "FIXED" (with short "FLOAT" transition time) when computing a position in RTK mode for the primary antenna. Press one of the vertical keys to see the computed position for the primary antenna (marked ①) and the secondary antenna (marked ②).

When corrections are received and used,  is displayed on the General Status screen together with the age of corrections (see *General Status on page 27*).

To configure the receiver as a Dual RTK rover, use the Web Server as follows:

- Go to **Receiver > Position > Rover Setup**.

- Set **Processing Mode** to **Dual RTK**.

- Specify how the corrections are being forwarded to the receiver by setting **Input Mode** accordingly.

If you choose **Automatic**, the receiver will find by itself which of its ports are used to acquire corrections.

If you choose **Manual**, you need to specify each of the two ports. The “**RTK-1**” line will define the port routing the corrections allowing the receiver to compute the position of the primary antenna, whereas the “**RTK-2**” line will define the port routing the corrections allowing the receiver to compute the position of the secondary antenna.

NOTE: The same set of corrections, hence the same port, can be used for both antennas.

- Additionally, in the **Other Settings** section, you may change the primary GNSS system used (**GPS** is the default selection), limit the level of position accuracy to less than what the receiver can actually achieve in this case. Typically you will choose **RTK Position** to match to the selected operating mode.
- Select the model of dynamics that suits the movement pattern of your rover best.
- Click **Configure**.
- Set the device used by the receiver to acquire corrections:
 - If corrections are received via radio, go to **Receiver > Radio** to enter all radio parameters. You may use the internal radio or an external radio.
 - If corrections are received over the Internet, go to **Receiver > Network** to set the device used (this may be Ethernet, Modem or WiFi; more information about how to set up these devices can be found in the relevant context-sensitive Help). Then go to **Receiver > I/Os** to start data reception in NTRIP or Direct IP mode.

Dual-Relative RTK

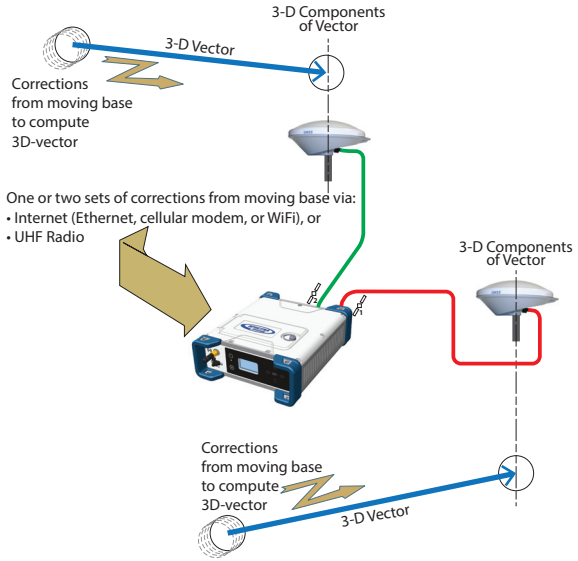

To configure the receiver as a Dual Relative RTK rover, use the Web Server as follows:

- Go to **Receiver > Position > Rover Setup**.
- Set **Processing Mode** to **Dual Relative RTK**.
- Select how the corrections are being transmitted to the receiver by setting **Input Mode** accordingly.

If you choose **Automatic**, the receiver will find by itself which of its ports are used to acquire corrections.

If you choose **Manual**, you need to specify each of the two ports. The “**BRV-1**” line will define the port routing the corrections from a moving base allowing the receiver to compute the vector to the primary antenna, whereas the “**BRV-2**” line will define the port routing the corrections from a moving base allowing the receiver to compute the vector to the secondary antenna.

NOTE: The same set of corrections from the same moving base, hence the same port, can be used for both antennas.

- Additionally, in the **Other Settings** section, you may change the primary GNSS system used (**GPS** is the default selection), limit the level of position accuracy to less than what the receiver can actually achieve in this case. Typically you will choose **RTK Position** to match to the selected operating mode.

- Select the model of dynamics that suits the movement pattern of your rover best.
- Click **Configure**.
- Set the device used by the receiver to acquire corrections:
 - If corrections are received via radio, go to **Receiver > Radio** to enter all radio parameters. You may use the internal radio or an external radio.
 - If corrections are received over the Internet, go to **Receiver > Network** to set the device used (this may be Ethernet, Modem or WiFi; more information about how to set up these devices can be found in the relevant context-sensitive Help).

Programming Data Outputs

The reader is supposed to know how to run the Web Server (see *Getting Started With the Web Server on page 47*) before reading this section.

Remember, when using the Web Server, at any time you can access context-sensitive help by pressing this key:



- Go to **Receiver > I/Os > Input Setup and Output Messages**.
In the right-hand part of the Web Server window, all receiver ports are listed, and for each of them, you can read the message or messages currently programmed to be output on this port at the specified data rate(s).
- To add or modify a message on a port, click on the line corresponding to that port. This updates the left-hand part of the window from which you can add or modify as many messages as you wish.

You may need to re-select the matching category in the upper field to access the desired message. For example if NMEA and ATOM messages are programmed on a given port, re-select ATOM in the upper field to access the definition of the ATOM messages. Same applies to NMEA messages.

For any further question about how to handle messages, please refer to the on-line Help.

Rover Output Messages

You will typically set a rover to generate NMEA messages to deliver its computation results (see complete list on *page 79*). Note that part of these results are also visible on the receiver front panel and in the right-hand section of the Web Server window.

You will typically ask the receiver to output the following NMEA messages:

- One GNSS antenna used:

Output	NMEA Message
Position (Autonomous, SDGPS, RTK, Hot Standby RTK or RTX)	GGA
Relative RTK	VCR

- Two GNSS antennas used:

Output	NMEA Message
Heading	HDT VCT HPR
Dual RTK*	GGA
Dual Relative RTK*	VCR

* When the same types of NMEA messages are output on the same port for the two GNSS antennas, special markers are inserted into the flow of messages so that the recipient device can recognize which messages are coming from which antenna.

For example the output of GGA messages will look like this:

```
$PASHD,#1,123456.00,ABCD,BEG*cc<cr><lf>
$GPGGA,...
$PASHD,#1,123456.00,ABCD,END*cc<cr><lf>
$PASHD,#2,123456.00,ABCD,BEG*cc<cr><lf>
$GPGGA,...
$PASHD,#2,123456.00,ABCD,END*cc<cr><lf>
```

Each NMEA message is inserted between a beginning (BEG) and end (END) marker (shown in bold characters in the example above). The marker header indicates for which antenna the NMEA message that immediately follows refers to. For example, a GGA message inserted between two “\$PASHD,#1,..” lines means the message is about the primary antenna. Same for VCR.

Base Data Messages

You will typically use a base to generate ATOM RNX messages. RTCM and CMR/CMR+ are also possible options. Program this output on port D if you are using the internal radio to broadcast these messages. Use port A, B or F if you are using an external radio connected to either of these serial ports.

Program this output on an IP port if your base is broadcasting its messages over the Internet:

- To an external NTRIP caster
- To the embedded NTRIP caster (see Web Server Online Help file)
- To an external IP server (receiver in client mode)
- To port I (8888) or J (8889) (receiver in server mode) in different modes (single or multiple connections).

Raw Data Recording

A default raw data output exists, which you should not modify unless you have specific needs. This output is made available on port M, which, at user's choice, stands for either the receiver's internal memory or a USB device (USB key or hard disk). Port M is the port used to save the collected raw data as a G-file.

Memory	Internal Memory	M	-	ATOM-PVT(1 Hz) ATOM-ATR ATOM-NAV/ ATOM-DAT ATOM-RNX-0(1 Hz) ATOM-OCC
--------	-----------------	---	---	---

This output consists of the following ATOM messages:

- PVT: Positioning results
- ATR: Attributes (antenna parameters, receiver description)
- NAV: Satellite navigation information
- DAT: Raw navigation data
- RNX-0: Receiver observations
- OCC: Site occupation information

G-files can be processed in *SPSO* (Spectra Precision Office Software) or by the *RINEX converter* utility.

When two antennas are used, note that by default, only PVT, ATR and RNX-0 are recorded for the secondary antenna.

Memory	Internal Memory	M	-	ATOM-PVT(1 Hz) ATOM-ATR ATOM-NAV/ ATOM-DAT ATOM-RNX-0(1 Hz) ATOM-OCC	ATOM-PVT(1 Hz) ATOM-ATR ATOM-RNX-0(1 Hz)
--------	-----------------	---	---	---	--

Available NMEA Messages

See details in Appendix.

Name	Description
ALR	Alarms
ARA	True heading
ARR	Vector & Accuracy
ATT	True heading
AVR	Time, yaw, tilt
BTS	Bluetooth status
CAP	Received base antenna
CPA	Received antenna height
CPO	Received base position
DDM	Differential decoder message
DDS	Differential decoder status
DTM	Datum Reference
GBS	GNSS Satellite Fault Detection
GGA	GNSS position message
GGK	GNSS position message
GGKX	GNSS position message
GLL	Geographic position - Latitude/Longitude
GMP	GNSS Map Projection Fix Data
GNS	GNSS Fix Data
GRS	GNSS Range Residuals
GSA	GNSS DOP and Active Satellites
GST	GNSS Pseudo-range Error Statistics
GSV	GNSS Satellites in View
HDT	True heading
HPR	True heading
LTN	Latency
MDM	Modem state and parameter
POS	Position
PTT	PPS time tag
PWR	Power status
RCS	Recording status
RMC	Recommended Minimum Specific GNSS Data
SBD	BEIDOU Satellites Status
SGA	GALILEO Satellites Status (E1,E5a,E5b)
SGO	GALILEO Satellites Status (E1,E5a,E5b,E6)
SGL	GLONASS Satellites Status
SGP	GPS Satellites Status
SIR	IRNSS Satellites Status
SLB	L-Band Satellites Status
SQZ	QZSS Satellites Status
SSB	SBAS Satellites Status
TEM	Receiver temperature
THS	True heading and status
TTT	Event marker
VCR	Vector and accuracy
VCT	Vector and accuracy
VEL	3D velocity and velocity accuracy
VTG	Course Over Ground and Ground Speed
ZDA	Date and time

Data Recording Sessions

Sessions are periods of time in a day during which you want automatic raw data recording to take place. Sessions are repeated every day. Creating sessions spanning over 24 hours therefore results in round-the-clock raw data recording.

To program sessions, run the Web Server and go to **Receiver> Sessions**. Most of the functions controlling sessions are grouped there. You may need to open the **Satellites** tab to change the **Raw Data Elevation Mask** parameter if needed.

The receiver front panel provides little control on sessions: You can only enable or disable sessions from there.

Creating Sessions

You can create two independent batches of sessions running in parallel:

- **Session batch #1**
- **Session batch #2**

The purpose of having two independent batches of sessions is to be able to record simultaneously different raw data at different rates and in different files.

Each of these two batches may consist of up to 288 sessions.

Sessions are identified with letters, as listed below:

- Sessions 1 to 24: A to X
- Sessions 25 to 48: AA to XA
- Sessions 49 to 72: AB to XB
- Sessions 73 to 96: AC to XC
- Sessions 97 to 120: AD to XD
- Sessions 121 to 144: AE to XE
- Sessions 145 to 168: AF to XF
- Sessions 169 to 192: AG to XG
- Sessions 193 to 216: AH to XH
- Sessions 217 to 240: AI to XI
- Sessions 241 to 264: AJ to XJ
- Sessions 265 to 288: AK to XK

The duration of a session will determine the period of time covered by the raw data file recorded during the session (minimum duration: 5 minutes).

For example, a one-hour session will result in a one-hour raw data file.

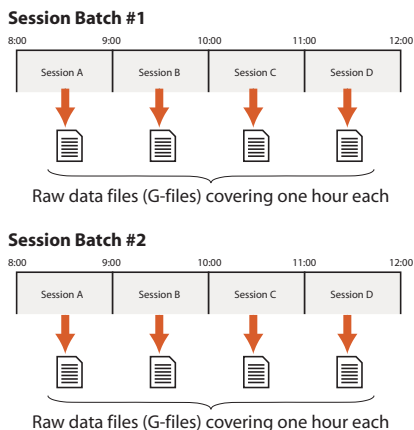

NOTE: Data recording can also take place out of any sessions through the Web Server's **Data Recording** function.

In each session batch, sessions can be created either automatically (in this case they are all of the same duration), or created individually through a manual procedure.

The two methods can be combined. For example, sessions can first be created automatically and then adjusted manually and individually, if necessary. The following parameters can be edited for each session individually: session start and end times, recording interval and data recording control. No session overlapping is allowed. Doing so would result in an error message.

Sleep mode: The receiver can be configured to be powered down automatically at the end of each session, provided these sessions are part of **Session Batch #1** and there is enough idle time between an ending session and the next one. The receiver will wake up automatically just before the next session (from session batch #1) is due to start.

Two additional options exist that may affect the way the programmed sessions are executed:

- **Reference Day** (1-366): This is the day when the execution of the programmed sessions should start. This option should be used when you want the receiver to start executing sessions only several days after having configured the receiver.

The principle is the following: If the current day is prior to the **Reference Day**, the receiver will wait until that day before starting running the sessions. If it is after, the

receiver will be allowed to start the sessions on the current day, according to the programmed sessions.

For example, with **Reference Day**=33 (Feb 2), if the current day is 30 (Jan 30), the receiver will start the first session only in three days, whereas if the current day is 51 (Feb 20), the receiver will start the programmed sessions on that day.

If you do not need to postpone the execution of the sessions, keep the default value ("1") for this option.

- **Offset per Day** (in minutes and seconds): This option is specifically designed for users who wish to have the same sky view of the GPS constellation every day. As the time when the GPS constellation comes back to a given sky view is 4 minutes earlier every day, setting this option to 04'00" will correct for this offset (i.e. this will allow the same GPS sky view to be observed every day through each of the sessions).

With **Offset per Day**=4'00", a session initially set to start at 9:00 for example will start at 8:56 on the second day, at 8:52 on the third day, etc. The same rule applies to the session end time, and to all the other programmed sessions.

If you do not need to offset the sessions, keep the default value (0'00") for this option.

Raw Data Types and Files Collected During Sessions

The types of raw data collected during sessions are those you have set on port S (for session batch #1) or port N (for session batch #2). In addition, the amount of collected raw data is tied to the value you give to **Raw Data Elevation Mask** (See **Receiver> Satellites** on the Web Server).

Raw data are saved as *G-files*, using the same naming convention as the one used in manual recording. A specific **Site Name** can be defined for files recorded through sessions. The file naming convention used is given below:

G<SiteName><Index><Year>.<Day>

Example: GPT12C17.030 is the third G file (C) collected on Jan 30, 2017 on a site named PT12.

Storing G-Files Collected During Sessions

G-files are saved either in the receiver's internal memory or on a USB device, i.e. on the mass storage device connected to the receiver via its USB port. In both cases, G-files are all saved to the root directory of the selected storage device.

At this stage, special mention should be made of the **Ring File Memory**. With this option activated, the receiver will be able to collect data for an unlimited period of time without external intervention. In practice, this option will allow the receiver to automatically delete the oldest file when the amount of available free memory (in the selected storage device) drops below 600 MBytes.

Converting, Compressing, Deleting G-Files Collected During Sessions

G-files can be converted to a variety of RINEX formats (from version 2.10 to version 3.03). This will happen only if the navigation data included in the G-file are in ATOM format (the conversion will otherwise fail).

You should be aware of the limitation in asking for RINEX conversion. The receiver won't convert to RINEX all G files resulting from sessions whose duration is less than 5 minutes.

The receiver can automatically complete the RINEX file header while converting G-files to RINEX files. The fixed additional information you would like the receiver to insert into that header can be entered using **Receiver> Memory > RINEX Metadata** on the Web Server.

RINEX files resulting from the conversion of G-files may be compressed to Hatanaka or/and Tar.Z.

If not converted to RINEX, G-files will always be Hatanaka compressed and possibly Tar.Z compressed if desired.

The file conversion/compression may be followed by the deletion of the original G-file, if desired.

Moving Files Originating from Sessions

The collected G-files and converted files may be moved to another location on the receiver. The purpose is to be able to sort the files according to the date of creation and the site of data collection.

The storage medium used in the file moving function may be different from the one initially used to store G-files. For example, the receiver may be asked to store the original G-files in its internal memory and then you can ask that the G-files and converted files be moved to the USB device.

When doing that, the receiver will automatically create subdirectories according to the rules you will have specified earlier. Typically, the receiver may create this type of tree structure as new files are collected:

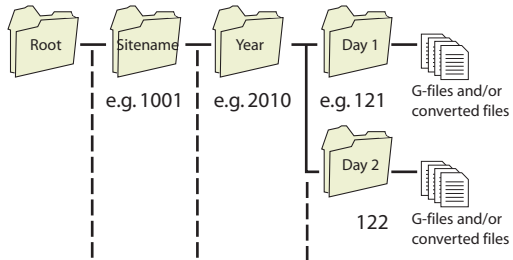

Organizing the storage of the files is simply obtained by typing the appropriate codification of the subdirectories in the field named **Sub-directory Name Format**. This field uses a specific syntax with case-sensitive characters. A typical syntax used is the following:

S/Y/D

Where each letter tells the receiver in which order to create the subdirectories and how to name them (see table below).

Character	Description
s or S	4-character sitename
Y	4-digit year (2017= 2017)
y	2-digit year (17= 2017)
m	2-digit month (01= January)
M	3-character month (Jan= January)
d	2-digit day in month (1-31)
D	3-digit day in year (1-365)

Pushing Files Originating from Sessions to a Primary FTP Server - Backup FTP Server

Parallel with the file moving function, the converted files may be pushed automatically to an external FTP server (the “primary” FTP server) through an IP connection, using the FTP communication protocol (activate the **Automatic Transfer** option in **Receiver> Sessions> Settings** on the Web Server). End users will then be able to connect to that FTP server for downloading the data they need for their applications.

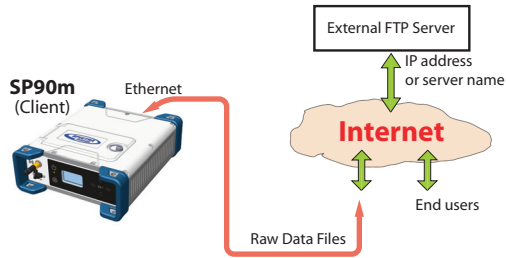

The receiver being the client for this transfer, you need to enter the IP address (or host name) and IP port of the remote FTP server, and also enter the login and password that will let the receiver upload its files to the server (see **Receiver> Sessions> External FTP Servers** on the Web Server).

You can also sort the files while transferring them to the FTP server. This is done using the same method as in the file moving function (a dedicated **Sub-directory Name Format** field also exists in this case of use).

By default the created tree structure is attached to the root directory of the FTP server. Using the **Path** field, you can attach the tree structure to the subdirectory the FTP server owner will have assigned to you. For example, typing **Path= ARCH5212** or **Path= /ARCH5212/** (the first and last slashes are optional), means your subdirectories will be created in the ARCH5212 subdirectory.

You can ask the receiver to delete the files from its memory after it has pushed them to the external FTP server. This is achieved by enabling the **Delete Files After Transfer** option (see **Receiver> Sessions> Settings** on the Web Server).

To make sure the files are always available to users, a backup FTP server can be made ready. The backup FTP server will use the same file organization as the one defined for the primary FTP server (through the above-mentioned **Sub-directory Name Format** field). The backup FTP server can be used in two different ways:

- Temporarily, following a failure of the primary FTP server. The backup FTP server will then instantly take over the role of the primary FTP server.
At the beginning of each new session, the SP90m checks to see if the primary FTP server is back to work and accessible. If that is the case, files will be pushed back to the primary FTP server (and the backup FTP server will stay idle in the background).
- Permanently, as a second repository for all the files collected by the receiver.

Recording Raw Data Outside of Any Sessions

Raw data recording can also take place outside of any sessions. What's more, it can take place simultaneously with data recording performed through the programmed sessions. This alternate recording capability can be controlled through **Receiver> Memory** on the Web Server.

Like with sessions, this type of data recording produces a G-file but the recorded data are those set on the port corresponding to the storage medium used (and not on port S or N). If for example the internal memory is used to save the G-file, then the recorded data will be those set on port M.

The settings are very similar to, while independent of, those found for session batches (i.e. site name, recording interval, ring file memory). For example raw data can be collected at 1 Hz through sessions while those collected through the Recording function may be at 20 Hz. Also a different site name may be used so that you can easily identify the data collected through the Recording function from those collected through sessions.

As with sessions, the **Ring File Memory** option may be used in this case to manage the free memory space. When this space drops below 600 MBytes, the older raw data file will be deleted to keep a minimum of free space on the storage medium used.

Embedded NTRIP Caster

Introduction

The *Embedded NTRIP Caster* is a firmware option allowing you to build your own NTRIP network solution around the SP90m receiver.

The embedded NTRIP caster can handle a total of 100 users and 10 mount points. The number of 100 users should be understood at the total number of possible users, irrespective of the mount points they are using. For example, if 90 users are connected to mount point n , then only a total of 10 users can be connected to any of the other possible mount points.

One of the distinguishing features of SP90m is its capacity to accommodate internally two NTRIP servers directly “feeding” the embedded NTRIP caster. The other NTRIP servers, if any (up to 8), will therefore be all external to the SP90m.

- The two internal NTRIP servers will both provide correction data from the “base” section of the SP90m (see figure below), typically in different formats.
- *Internal NTRIP server 1* uses Ethernet port P to deliver its correction data to the caster. The correction data are internally routed from the base either through the internal modem or directly via Ethernet.
- *Internal NTRIP server 2* uses Ethernet port Q to deliver its correction data to the caster. The correction data can only be routed internally from the base via Ethernet.

The figure below shows the internal architecture of the SP90m when the *Embedded NTRIP Caster* firmware option is enabled and running and two internal NTRIP servers are also set up and running.

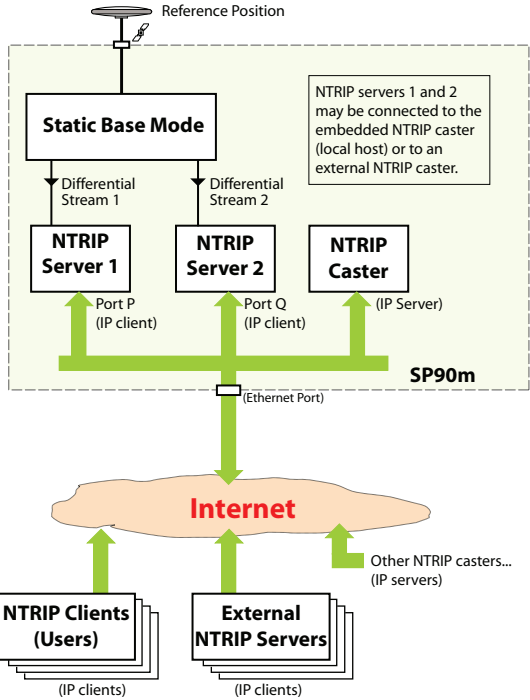

In its simplest configuration, the embedded NTRIP caster can be used to emulate the Direct IP mode (i.e. IP connection to a unique source of corrections), with the additional advantage that, contrary to conventional Direct IP, the embedded NTRIP caster can offer an effective protection of the source of corrections by restricting its access to the sole authorized users.

In this application, the SP90m makes use of both its embedded NTRIP caster and an internal NTRIP server (see figure below):

- In the NTRIP caster, a single mount point is available and all authorized users are allowed to use this mount point.
- The internal NTRIP server is connected to the NTRIP caster's unique mount point.

The result is that only the NTRIP caster users are allowed to use the source of corrections.

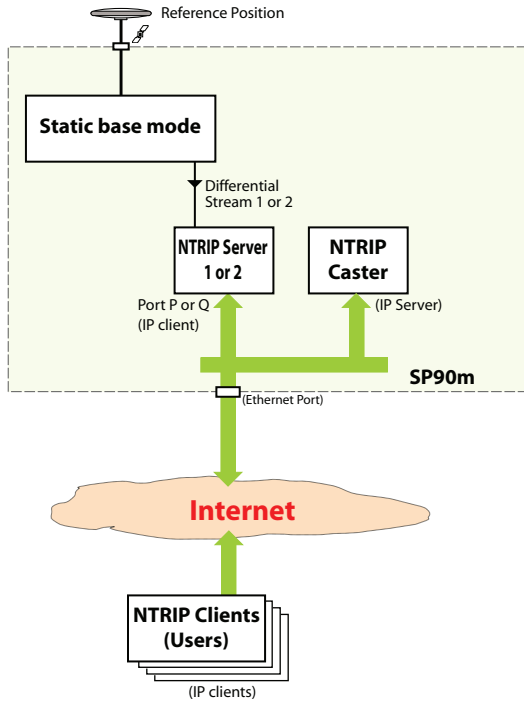

NTRIP Caster Control & Monitoring

The Web Server provides an easy way to remote control and monitor the Embedded NTRIP caster.

Once the Embedded NTRIP Caster firmware option has been activated in the receiver, the Web Server shows the **Embedded NTRIP Caster** button in the upper part of the window.

The **Embedded NTRIP caster** option is split into three submenus:

- The **Settings** submenu allows you to control the NTRIP caster function (ON/OFF), enter the public IP address of the caster, specify the unique password that all NTRIP servers will need to provide if they want to be authorized as a recognized source of corrections for the caster, and the maximum number of simultaneous connections accepted per user (default: 1). The submenu also allows you to provide all the informative data usually found in an NTRIP source table (this information is forwarded to users when querying the NTRIP caster).

- The **Mount Points** submenu allows you to define each of the possible 10 mount points of the NTRIP caster. Choosing the name of a mount point is important:
 - It is through that name that NTRIP servers can connect to the NTRIP caster.
 - It is through that name that users can choose which base station they want to receive correction data from.

Informative data for each mount point can also be defined on this submenu, such as the approximate position of the base that will provide correction data through this mount point, the country where it's located, whether using the data from this base is free or not, and whether the receiver should be provided the user position in an NMEA message or not before delivering its corrections.

Each mount point definition appears in the table at the bottom of the page. You can easily modify each of them by selecting the corresponding row in the table.

- The **Users** submenu allows you to define all the possible users of the NTRIP caster. Defining a new user includes specifying a user name and password, as well as the allowed mount points. Refer to *Protecting Mount Points on page 91* for more information on the impact of explicitly assigning mount points to users.

Each user definition appears in the table at the bottom of the page. You can easily modify each of them by selecting the corresponding row in the table.

In the right-hand part of the **Embedded NTRIP caster** web page are four submenus:

- The **Current** submenu provides the list of mount points through which sources of correction data are currently available, as well as the list of currently connected users. Each user is clearly identified (name, mount point used, time when connection started, IP address).
- The **History** submenu provides the same type of information as the **Current** submenu, with in addition the list of past connections (start and end times, users, mount points, IP addresses) since the NTRIP caster was started. It is in fact a more friendly way of representing the content of the log file presented below.
- The **Log file** submenu views the raw content of the log file gathering all the events in relation with the embedded NTRIP caster since it was started.
- The **Map** submenu provides a map of the NTRIP caster network using different colors to show the location of the

caster, of the NTRIP servers (bases) and of the different users.

Protecting Mount Points

Protecting mount points may be done in an indirect way, as explained below:

- Not assigning a mount point to any of the registered users implies that this mount point is accessible to anyone who can make an IP connection to the NTRIP caster. Besides, the NTRIP caster may list mount points that are not registered as managed by the NTRIP caster. If such mount points are available, anyone who can make an IP connection to the NTRIP caster will be allowed to connect to these mount points.
- Conversely, from the moment a mount point is assigned to a registered user, this mount point is no longer accessible to all. Only registered users explicitly granted the right to connect to that mount point will actually be able to do so. As the administrator of the NTRIP caster, you can for example create a user for the sole purpose of protecting your mount points. Allowing this user to connect to all your mount points will amount to placing a protection, with immediate effect, on all these mount points, preventing anyone else to connect to them. Then you can gradually add new users allowed to connect to one or more of the protected mount points.
- In order to keep the NTRIP caster accessible to a maximum of registered users, you can limit the number of simultaneous connections allowed per user. Too many simultaneous connections from one user would indeed limit the number of possible connections for all other users.
- **Warning!** Having registered users not assigned to a single mount point means they can access all the mount points managed by the caster!

Embedded FTP Server

End users may download raw data files directly from the receiver memory. This can be done through the embedded FTP server, which gives remote access to the selected receiver memory and directory via an IP connection, using the FTP communication protocol.

In this case, end users should be given read access (through a user profile) to the directory containing the raw data files collected by the receiver.

Alternatively, as the owner of the receiver, you may have to perform remote maintenance operations in the receiver memory. This connection gives you full read/write control on the specified directory and child directories.

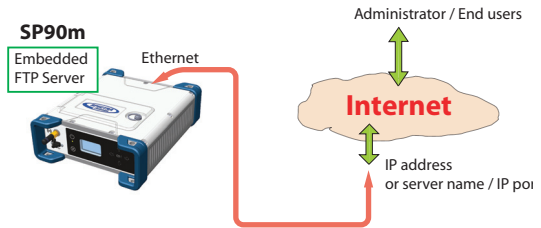

Communicating with SP90m Using a Mobile Phone

Introduction

The SP90m can receive and process specially formatted SMS's causing it to respond accordingly. This functionality gives you extra flexibility for remote control and monitoring of your SP90m.

Typically, you will use this functionality if you are operating your own base/rover system and, being at some distance from your base, you would like to communicate with it for monitoring or remote control purposes. The use of SMS's is however not restricted to communicating with a base: You can also use them to communicate with a rover.

SP90m's SMS functionality may be:

- Disabled
- Set up to process SMS's only from registered phone numbers.
- Or set up to process SMS's from any phone number.

By default, the SP90m accepts SMS's from any phone number. Any command you send should be in the form:

```
Command_name[<sp>parameter_1][<sp>parameter_2]
[<sp>parameter_3][<sp>parameter_4]
```

(Commands may be typed in using upper- or lower-case characters.)

Any response the remote SP90m returns will be in the form:

```
SP90m<sp>(Receiver Serial Number)
HH:MM:SS

Command_name[<sp>parameter_1][<sp>parameter_2]
[<sp>parameter_3][<sp>parameter_4]<sp>OK
[Optional_parameters_when_appropriate]
```

Where:

- <sp>: Space character
- {...}: Definition of the parameter you must type (and not the parameter itself).
- [...]: Parameter required for some commands only.
- Date expressed in day/month/year and time in hours:minutes:seconds.
- Line in bold characters: Command SMS sent to SP90m
- Line in normal characters: Response SMS from SP90m.

Commands List

Command Name & Syntax	Function
ANH VERT x.xx	Sets antenna height (vertical measurement)
ANH SLANT y.yy	Sets antenna height (slant measurement)
ANR OFF	Sets L1 phase center as reference location
ANR PC1	Sets L1 phase center as reference location
ANR ON	Sets ground mark as antenna reference location
ANR SPT	Sets ground mark as antenna reference location
ANR ARP	Sets ARP as reference location
ATH ON	Activates anti-theft function
ATH OFF {password}	Deactivates anti-theft function
GETID	Returns SP90m identification information
GETMEM	Returns memory status
GETPOS	Returns last computed position
GETPOWER	Returns power status
HELP	Returns the list of available commands
HELP {command name}	Returns the syntax of the specified command
MEM INT	Sets internal memory as current memory
MEM SD	Sets external SD card as current memory
MODE BASE	Sets the SP90m as a base receiver
MODE ROVER	Sets the SP90m as a rover receiver
POS...	Provides coordinates to be the reference position
POS CUR	Sets last computed position as reference position
RADIO ON	Powers up the radio
RADIO CHN INT {channel}	Sets channel number in internal radio device
RADIO CHN EXT {channel}	Sets channel number in external radio device
RADIO OFF	Turns off radio
REC ON	Starts data recording at currently set recording rate
REC ON 0.5	Same but you choose the recording rate
REC OFF	Stops data recording
SEND LOG n ...@...	Asks the SP90m to email its last "n" log files to the specified email recipient
SEND PAR ...@...	Asks the SP90m to email its operating parameters to the specified email recipient

See below for details.

ANH: Setting Antenna Height

Send this SMS to change the receiver antenna height. You can either send a vertical or slant measurement (both in meters) of the antenna height.

Command Syntax:

ANH<sp>VERT<sp>{vertical measurement}
or
ANH<sp>SLANT<sp>{slant measurement}

Example 1: Sending vertical height measurement

ANH VERT 2.124
SP90m 5703A00116
11:02:14

ANH VERT 2.124 m: OK

Example 2: Sending slant height measurement:

ANH SLANT 1.645
SP90m 5703A00116
11:02:14

ANH SLANT 1.645 m: OK

ANR: Setting Antenna Reduction Mode

Send this SMS to change the location for which the receiver computes a position.

Command Syntax:

- 1) Position computed for antenna L1 phase center location:

ANR<sp>OFF
or
ANR<sp>PC1

- 2) Position computed for ground mark location:

ANR<sp>ON
or
ANR<sp>SPT

- 3) Position computed for antenna reference point (ARP):

ANR<sp>ARP

Example:

ANR ON
SP90m 5703A00116
11:03:40

ANR ON: OK

ATH: Setting Anti-Theft

Send this SMS to enable or disable the anti-theft function. For example, anti-theft can be disabled remotely just at the end of a work day to allow another operator not working with a data collector to be able to fetch the base without causing the anti-theft alarm to go off.

Command Syntax:

1) Enabling anti-theft (be sure to know the password before you send this SMS):

ATH<sp>ON

2) Disabling anti-theft:

ATH<sp>OFF<sp>{password}

Example:

ATH ON
SP90m 5703A00116
11:04:25

ATH ON: OK

GETID: Reading Receiver Identification Information

Send this SMS to query the receiver for its serial number, firmware version and warranty expiration date. (The SP90m serial number is part of almost every SMS the SP90m sends back in response to a command.)

Command Syntax:

GETID

Example:

GETID
SP90m 5703A00116
11:05:01

Version: 2.00
Version date: 01/10/2017
Expiration date: 01/10/2019

GETMEM: Reading Memory Status

Send this SMS to query the receiver for the status of the currently used memory.

Command Syntax:

GETMEM

Example:

GETMEM
SP90m 5703A00116
11:08:29

Current memory: internal
Free memory: 1.4GB (99%)
G-Files: 3
ATL Files: 1
Free SD Card: 7.2GB (99%)
G-Files: 2
ATL Files: 0

GETPOS: Reading Computed Position

Send this SMS to query the receiver for the last computed position.

Command Syntax:

GETPOS

Example:

GETPOS

SP90m 5703A00116
11:11:17

47 17'12.12345"N
001 30'14.54321"W
+75.254 m (SPT)
Type: FIXED
Mode: ROVER
Age: 1 s
Satellites: 22
Antenna height: 2.000 m (vert)

GETPOWER: Reading Receiver Power Status

Send this SMS to query the receiver for the current status of its power supply.

Command Syntax:

GETPOWER

Example:

GETPOWER

SP90m 5703A00116
11:13:47

Source: external power
Battery: 80% (7.3V)
External power: 12.2V

HELP: Reading the List of Commands

1. Send this SMS if you want to be reminded of all the possible commands you may use to control/monitor a receiver through SMS's.

Command Syntax and SP90m Response:

HELP

ANH

ANR

ATH

GETID

GETMEM

GETPOS

GETPOWER

MEM

MODE

POS

RADIO

REC

SEND

2. The receiver can return the syntax of each of the above commands by sending the following SMS:

HELP<sp>command_name

{Detail of command syntax returned}

+ Command explanation in plain

Example:

HELP MEM

MEM <INT/SD>

Sets recording memory

MEM: Setting Current Memory

Send this SMS to change the memory used by the receiver. This may be the internal memory or an external SD card connected to the receiver.

Command Syntax:

MEM<sp>INT
or
MEM<sp>SD

Example 1: Choosing the internal memory

MEM INT
SP90m 5703A00116
11:05:09

MEM INT: OK

Example 2: Choosing the external SD card:

MEM SD
SP90m 5703A00116
11:05:18

MEM SD: OK

MODE: Setting Receiver Mode

Send this SMS to change the receiver's operating mode: rover or base.

Command Syntax:

MODE<sp>BASE
or
MODE<sp>ROVER

Example 1: Selecting Base Mode

MODE BASE
SP90m 5703A00116
11:12:25

MODE BASE: OK

Example 2: Selecting Rover Mode

MODE ROVER
SP90m 5703A00116
11:12:45

MODE ROVER: OK

POS: Setting Reference Position

Send this SMS to change the receiver's reference position. You can choose to send the coordinates of this position or ask the receiver to use the last position it computed (and then keep the reference position to this value).

Command Syntax:

POS<sp>{Attribute}<sp>{Latitude}<sp>{Longitude}<sp>{Height}
 or
 POS<sp>CUR

Parameter	Description	Range
Attribute	Position attribute: <ul style="list-style-type: none"> • PC1: Position attached to L1 phase center (default) • ARP: Position attached to ARP (Antenna Reference Position) • SPT: Position attached to ground mark (surveyed point) 	PC1, ARP, SPT
Latitude	Latitude in degrees, minutes, seconds and fraction of second (5 decimal places) (ddmmss.sssss)	0 to ± 90
Longitude	Longitude in degrees, minutes, seconds and fraction of second (5 decimal places) (dddmmss.sssss)	0 to ± 180
Height	Height in meters	0 to ± 9999.9999

Example 1: Sending the coordinates of the reference position

POS PC1 471756.29054 -13032.58254 88.225

SP90m 5703A00116

11:20:25

SET BASE POSITION: OK

Type: PC1

Latitude: 47 17'56.29054"N

Longitude: 001 30'32.58254"W

Height: +88.225m

Example 2: Asking the receiver to use the last computed position as the reference position

POS CUR

SP90m 5703A00116

11:21:15

SET BASE POSITION: OK

Type: PC1

Latitude: 47 17'56.29054"N

Longitude: 001 30'32.58254"W

Height: +88.225m

RADIO: Setting the Radio

Send this SMS to control the radio attached to the SP90m.

Command Syntax:

1) Turning on the internal radio:

RADIO<sp>ON

2) Setting the radio channel after turning on the radio:

RADIO<sp>CHN<sp>{internal_or_external_radio}<sp>{radio_channel}

3) Turning off the internal radio:

RADIO<sp>OFF

Example 1: Turning on the radio:

```
RADIO ON  
SP90m 5703A00116  
11:18:05
```

RADIO ON: OK

Example 2: Setting the internal radio to use channel 2:

```
RADIO CHN INT 2  
SP90m 5703A00116  
11:13:05
```

```
RADIO CHN INT 2: OK  
Channel: 2  
RX Frequency: 444.0000MHz  
TX Frequency: 445.0000MHz
```

NOTE: The SP90m response also returns the two frequencies corresponding to the choice of a given channel.

Example 3: Turning off the radio:

```
RADIO OFF  
SP90m 5703A00116  
11:27:16
```

RADIO OFF: OK

REC: Setting the Recording Mode

Send this SMS to control raw data recording in a remote SP90m.

Command Syntax:

1) Starting recording raw data to the current memory at the currently selected recording rate:

REC<sp>ON

2) Starting recording raw data to the current memory at the specified recording rate:

REC<sp>ON<sp>{recording_rate}

3) Ending raw data recording:

REC<sp>OFF

Example 1: Starting raw data recording at 0.1 second:

REC ON 0.1

SP90m 5703A00116

11:32:04

REC ON 0.10: OK

Example 2: Ending raw data recording:

REC OFF

SP90m 5703A00116

11:35:19

REC OFF: OK

**SEND LOG:
Emailing Log Files**

Send this SMS to ask the remote SP90m to email its last log files to the specified email address.

Command Syntax:

SEND<sp>**LOG**<sp>{x_last_log_files}<sp>{email_address}

Example: Emailing the last 4 log files to the specified email address:

SEND LOG 4 rxg217@mmwerx.com
SP90m 5703A00116
11:40:11

SEND LOG 4 rxg217@mmwerx.com: OK
4 log file(s) sent

**SEND PAR:
Emailing Receiver
Parameters**

Send this SMS to ask the remote SP90m to email all its operating parameters to the specified email address.

Command SMS Syntax:

SEND<sp>**PAR**<sp>{email_address}

Example: Emailing all SP90m operating parameters to the specified email address:

SEND PAR rxg217@mmwerx.com
SP90m 5703A00116
11:42:51

SEND PAR rxg217@mmwerx.com: OK

Notification E-mails

As the administrator of the SP90m receiver, you may configure your system to be informed via email of possible malfunctions detected by the receiver. This will allow you to quickly respond to the email alert by taking the appropriate maintenance steps.

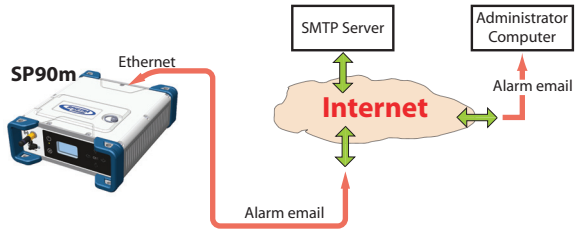

You may choose between three different levels of notification:

- **Full notification.** Each of the following events will generate an email:
 - “High” and “medium” alarms
 - Receiver powered on
 - Power shutdown causing the receiver to operate from its internal battery.
- **Standard notification.** Each of the following events will generate an email:
 - “High” alarms only
 - Receiver powered on
 - Power shutdown causing the receiver to operate from its internal battery.
- **No notification** at all.

Remember the receiver may report three categories of alarms:

- “High” alarms, indicative of serious problems
- “Medium” alarms
- “Low” alarms

The receiver is not designed to process incoming emails. It is therefore no use replying to an alarm email.

Example of notification email:

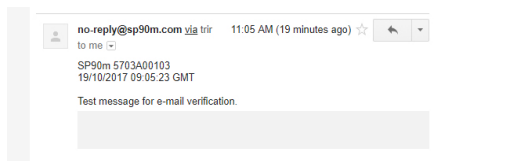

Specifications **GNSS Engine**

- 480 GNSS tracking channels:
 - GPS L1 C/A, L1P (Y), L2P (Y), L2C, L5, L1C
 - GLONASS L1 C/A, L1P, L2 C/A, L2P, L3, L1/L2 CDMA ⁽¹⁾
 - GALILEO E1, E5a, E5b, E6
 - BeiDou B1, B2, B3 ⁽¹⁾
 - QZSS L1 C/A, L1s, L1C, L2C, L5
 - IRNSS L5
 - SBAS L1 C/A, L5
- Two MSS L-band tracking channels
- Two GNSS antenna inputs ⁽²⁾

Features

- Patented Z-tracking to track encrypted GPS P(Y) signal
- Patented Strobe™ Correlator for reduced GNSS multi-path
- Patented Z-Blade technology for optimal GNSS performance:
 - Highest quality of raw data (availability/reliability) to meet reference station applications
 - Full utilization of signals from all seven GNSS systems (GPS, GLONASS, BeiDou, Galileo, QZSS, IRNSS, and SBAS)
 - Enhanced GNSS-centric algorithm: fully-independent GNSS signal tracking and optimal data processing, including GPS-only, GLONASS-only or BeiDou-only solution (autonomous to full RTK) ⁽³⁾
 - Fast and stable RTK solution
 - Fast Search engine for quick acquisition and re-acquisition of GNSS signals
- Patented SBAS ranging for using SBAS code & carrier observations and orbits in RTK processing
- Position in local datums and projections with RTCM-3 transformation data
- Support for Trimble RTX™ real-time correction services
- Support for CenterPoint® RTX Post-processing service
- UHF networking

- Hot Standby RTK Algorithms
- Flying RTK Algorithms
- RTK base and rovers modes, post-processing mode
- Moving base
 - RTK with Static & Moving Base corrections supported
 - Multi-dynamic mode (static/moving Base and Rover functions simultaneously)
 - RTK against a moving base for relative positioning
- Heading and Roll/Pitch
 - Accurate and fast heading using dual-frequency, multi-GNSS algorithms
 - RTK or Trimble RTX and heading processing simultaneously
 - Heading engine with optional baseline length self-calibration
 - Adaptive velocity filter to meet specific dynamic applications
- Adaptive velocity filter to meet specific dynamic applications.
- Up to 50 Hz real-time raw data (code & carrier and position, velocity, and heading output) ⁽⁴⁾
- Reference Inputs/Outputs: RTCM 3.2 ⁽⁵⁾, RTCM 3.1/3.0/2.3/2.1, CMR/CMR+, ATOM ⁽⁶⁾
- Supported RTK networks: VRS, FKP, MAC
- NTRIP protocol
- Navigation outputs: NMEA-0183, ATOM
- PPS output
- Event marker input
- One-push Ashtech Trouble Log (ATL)

GNSS Sensor Performance

- Time to First Fix (TTFF):
 - Cold start: < 60 seconds
 - Warm Start: < 45 seconds
 - Hot Start: < 11 seconds
 - Signal re-acquisition: < 2 seconds
- Position accuracy (HRMS), SBAS: < 50 cm (1.64 ft) ⁽⁷⁾
- Update rate: Up to 50 Hz ⁽⁴⁾
- Latency: < 10 ms ⁽⁸⁾
- Velocity Accuracy: 0.02 m/sec HRMS

- Maximum Operating Limits ⁽⁹⁾
 - Velocity: 515 m/sec
 - Altitude: 18,000 m

Precise Positioning Performance

Real-Time Accuracy (RMS) ⁽¹⁰⁾ ⁽¹¹⁾

- Real-Time DGPS Position:
 - Horizontal: 25 cm (0.82 ft) + 1 ppm
 - Vertical: 50 cm (1.64 ft) + 1 ppm
- Real-Time Kinematic Position (RTK):
 - Horizontal: 8 mm (0.026 ft) + 1 ppm
 - Vertical: 15 mm (0.049 ft) + 1 ppm
- Network RTK ⁽¹²⁾:
 - Horizontal: 8 mm (0.026 ft) + 0.5 ppm
 - Vertical: 15 mm (0.049 ft) + 0.5 ppm

Trimble RTX™ (Satellite and Cellular/Internet (IP)) ⁽¹³⁾ ⁽¹⁴⁾

- CenterPoint® RTX
 - Horizontal (HRMS): < 4 cm
 - Initialization: < 30 min. (typical)
 - Operating range (inland): Nearly worldwide
- CenterPoint RTX Fast
 - Horizontal (HRMS): < 4 cm
 - Initialization: < 5 min. (typical)
 - Operating range (inland): In select regions

Heading ⁽¹⁵⁾ ⁽¹⁶⁾ ⁽¹⁷⁾

- Accuracy (RMS):
 - 0.09° for 2 meters of baseline length
 - 0.02° for 10 meters of baseline length
- Initialization time: < 10 sec typical
- Baseline length: < 100 m

Flying RTK

- 5 cm (0.165 ft) + 1 ppm (steady state) horizontal for baselines up to 1000 km

Real-Time Performance

(10) (11)

- Instant-RTK® Initialization:
 - Typically 2-second initialization for baselines < 20 km
 - Up to 99.9% reliability
- RTK initialization range:
 - > 40 km

Post-Processing Accuracy (RMS)

(10) (11)

Static, Rapid Static:

- Horizontal: 3 mm (0.009 ft) + 0.5 ppm
- Vertical: 5 mm (0.016 ft) + 0.5 ppm

High-Precision Static ⁽¹⁸⁾:

- Horizontal: 3 mm (0.009 ft) + 0.1 ppm
- Vertical: 3.5 mm (0.011 ft) + 0.4 ppm

Post-Processed Kinematic:

- Horizontal: 8 mm (0.026 ft) + 0.5 ppm
- Vertical: 20 mm (0.065 ft) + 1.0 ppm

Data Logging Characteristics

- Recording Interval: 0.02 ⁽¹⁹⁾-999 seconds

Memory

- 8 GB internal memory
- Memory is expandable through external USB sticks or hard drives
- Over four years of 15 sec. raw GNSS Data from 14 satellites (logged to internal 8GB Nand Flash)

Embedded Web Server

- Password-protected Web Server
- Full receiver monitoring and configuration
- FTP push function
- Embedded FTP server and NTRIP caster ⁽²⁰⁾
- NTRIP Server and instant real-time multi-data streaming over Ethernet
- DHCP or manual configuration (static IP address)
- DynDNS® technology support

User and I/O Interface

- User Interface:
 - Graphical OLED display with 6 keys and 1 LED
 - WEB UI (accessible via WiFi or Ethernet) for easy configuration, operation, status and data transfer
- I/O interface:
 - 1 x USB OTG
 - Bluetooth v4.0 + EDR/LE, Bluetooth v2.1 + EDR
 - WiFi (802.11 b/g/n)
 - 3.5G quad-band GSM (850/900/1800/1900 MHz) / penta-band UMTS module (800/850/900/1900/2100 MHz)
 - 1 x Ethernet, RJ45 (Full-Duplex, auto-negotiate 10 Base-TX / 100 Base-TX)
 - 1 x Lemo, RS232 (radio connection and external power)
 - 1 x DB9, RS232 (PPS output and CAN bus)
 - 1 x DB9, RS422/232 (Event marker input)
 - 2 x TNC, GNSS antenna input
 - 1 x TNC, UHF radio antenna connector
 - 1 x SMA, GSM antenna connector
 - 1 x SMA, Bluetooth/WiFi antenna
 - PPS output
 - Event marker input
 - Galvanic Insulation (Except USB)
 - Ready for CAN bus (NMEA 2000 compatible)

Physical and Electrical Characteristics

- Size: 16.5 x 20.6 x 6.5 cm (6.5 x 8.1 x 2.6 in)
- Weight: GNSS receiver: 1.66 kg (3.66 lb) without UHF / 1.70 kg (3.75 lb) with UHF
- Battery life:
 - 4 hrs (RTK Base, GNSS On, UHF Tx On), 12.8 W average power consumption
 - 6 hrs (RTK Rover, GNSS On, UHF Rx On), 5.9 W average power consumption
- Li-ion battery, 27.8 Wh (7.4 V x 3.7 Ah). Acts as a UPS in case of a power source outage
- 9-36 V DC input (EN2282, ISO7637-2)
- External DC power limits feature

Environmental Characteristics

- Operating temperature ⁽²¹⁾: -40° to +65°C ⁽²²⁾ (-40° to +149°F)
- Storage temperature ⁽²³⁾: -40° to +95°C (-40° to +203°F)
- Humidity: Damp Heat 100% humidity, + 40°C (+104°F); IEC 60945:2002
- IP67 (waterproof and dustproof): IEC 60529
- Drop: 1m drop on concrete
- Shock: MIL STD 810F (fig. 516.5-10) (01/2000). Sawtooth (40g / 11ms)
- Vibrations: MIL-STD 810F (fig. 514.5C-17) (01/2000)

(1) Product is designed to fully support GLONASS L1/L2 CDMA and BeiDou B3 signals as soon as the officially published signal Interface Control Documentations (ICD) become available..

(2) Secondary GNSS antenna input is dual-frequency only (no GPS/SBAS/IRNSS L5, no Galileo E5a, E6, no Beidou B3, no GLONASS L3).

(3) All available GNSS signals are processed equally and combined without preference to any particular constellation for optimal performance in harsh environment.

(4) 50 Hz output is available as firmware option (20 Hz output is a standard feature). At 50 Hz, a limited set of messages can be generated simultaneously through a single port.

(5) RTCM-3.2 Multiple Signal Messaging (MSM) guarantees compatibility with 3rd party for each GNSS data.

(6) ATOM: Open Ashtech format.

(7) VRMS for Autonomous/SBAS positions are usually twice as high as HRMS.

(8) Heading latency is usually twice as high.

(9) As required by the U.S. Department of Commerce to comply with export licensing restrictions.

(10) Accuracy and TTFF specifications may be affected by atmospheric conditions, signal multipath and satellite geometry.

(11) Performance values assume minimum of five satellites, following the procedures recommended in the user guide. High multipath areas, high PDOP values and periods of severe atmospheric conditions may degrade performance.

(12) Network RTK PPM values are referenced to the closest physical base station.

(13) Requires L1/L2 GPS+GLONASS at a minimum.

(14) Accuracy and TTFF specifications may be affected by atmospheric conditions, signal multipath, satellite geometry and L-band service availability. Trimble RTX correction services are only available on land.

(15) Accuracy and TTFF specifications may be affected by atmospheric conditions, signal multipath, satellite geometry and corrections availability and quality

(16) L1/L2 data required.

(17) Figures of pitch accuracy are twice as high.

(18) Depending on baselines, precise ephemeris and long occupations up to 24 hrs may be required to achieve the high precision static specifications.

(19) A Recording Interval of 0.05 is based on a 20 Hz output. The default changes to 0.02 if the optional 50 Hz output firmware option is installed.

(20) Embedded NTRIP Caster is available as firmware option.

(21) Depends on whether the internal battery is used or not:

- With internal battery being charged: +45°C (+113°F) max.

- With internal battery being discharged: +60°C (+140°F)

- Without internal battery (external power supply): +65°C (+149°F) under conditions of installation.

At very high temperature, the UHF module should not be used in transmitter mode. With the UHF transmitter on radiating 2W of RF power, the operating temperature is limited to +55°C (+131°F).

(22) At this temperature, hand protection may be needed to safely handle the system's lower aluminum housing (as per EN60945).

(23) Without battery. Battery can be stored up to +70°C (+158°F).

NOTE: All performance values are given assuming a minimum of five satellites are used, and following the procedures recommended in the user guide. High multipath areas, high PDOP values and periods of severe atmospheric conditions may degrade performance.

1PPS Output

This output delivers a periodic signal that is a multiple or submultiple of 1 second of GPS time, with or without offset. Using the 1PPS output is a standard feature of the receiver (no firmware option needed).

The 1PPS output is available on port F, pin 9.

You can set the properties of the 1PPS signal using the `$PASHS,PPS` command. These properties are:

- Period: a multiple (1 to 60) or submultiple (0.1 to 1 in 0.1-second increments) of 1 second of GPS time.
- Offset: Amount of time in seconds before (+) or after (-) a full second of GPS time.

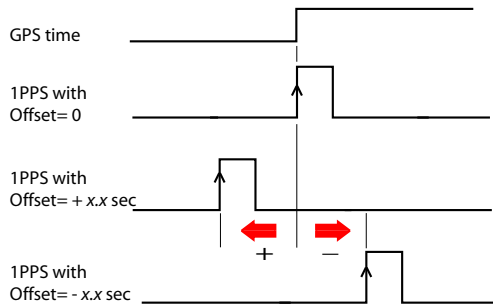

- Active edge, i.e. the edge (falling or rising) synchronized with GPS time. (On the diagram above, it is the rising edge that is set to be the active edge).

You can read the current properties of the 1PPS output using the `$PASHR,PPS` command.

The specifications for the 1PPS signal are as follows:

- Signal level: 0-5 V
- Pulse duration: 1 ms
- Jitter: < 100 ns
- Slope transient time: < 20 ns

You can also output the exact GPS time of the active edge of the 1PPS signal using the `$PASHR,PTT` command. The receiver will respond to this command right after the next 1PPS signal is issued, taking into account the chosen offset.

Event Marker Input

This input is used to time-tag external events. When an external event is detected on this input, the corresponding GPS time for this event is output as a \$PASHR,TTT message on any port. The time tag provided in the message represents the exact GPS time of the event to within 1 μ second. A single message is output for each new event.

Using the event marker input is a standard feature of the receiver (no firmware option needed).

The event marker input is available on port B, pin 7.

You can choose whether it will be the rising or falling edge of the event marker signal that will trigger the time tagging of the event. This choice can be done using the \$PASHS,PHE command.

The signal specifications of the event marker input are as follows:

- Signal level: ± 10 V
- Permitted transient time on active edge: < 20 ns

Resetting the Receiver

With the SP90m turned off, press the two horizontal arrow keys (right and left) AND the Power button simultaneously for a few seconds until the power LED turns green.



This starts the receiver. The screen first displays the Spectra Precision logo, then **Reset mode** is displayed for a while. At the end of this sequence, all receiver factory settings have been restored.

The following parameters, functions and devices are not impacted by the reset sequence:

- Last ephemeris data saved in the receiver (except for SBAS data)
- Last almanac data saved in the receiver
- Last position and time computed by the receiver
- Anti-theft status and parameters
- Startup protection status and parameters
- Ethernet device power status (will remain ON if it was ON before, or OFF if it was OFF) as opposed to all other devices (WiFi, Modem, Bluetooth)
- All settings (PIN code, APN, login, password, etc.) relevant to modem, Bluetooth, WiFi, Ethernet, Web Server
- SMS phone list, email address list and settings
- Automatic power-on and power-off settings
- Receiver validity period.

Upgrading the Receiver Firmware

This can be done in different ways:

- Using the Web Server. Go to **Receiver > Configuration > Firmware Upgrade**.
- USB key + OLED display (see *page 36*).
- USB key + key combination at receiver startup (see *page 45*).
- Using the *SP Loader* software utility (see below).

SP Loader Software Utility

Use Spectra Precision *SP Loader* software to:

1. Upgrade the receiver firmware
2. Install new firmware options based on the use of a POPN delivered to you following the purchase of one of these options.
3. Validate CenterPoint RTX subscription.
4. Read the warranty expiration date of a GNSS receiver.

Installing SP Loader

SP Loader can be downloaded from:

<http://www.spectraprecision.com/eng/sp90m.html#WUjSUdxLdhE>

(Click on the Support tab to access the download link.)

The install file is an executable file. Simply double-click on this file to start installation. Follow the instructions on the screen to complete the installation.

Getting Started With SP Loader

SP Loader will use either a serial (RS232), Bluetooth or USB connection to communicate with the receiver. USB is recommended.

1. Connect your computer to the SP90m using a USB connection.
2. Run SP Loader on your computer.
3. Select the computer's port ID used to communicate with the receiver. This port ID should correspond to the computer's USB port.

NOTE: An easy way to identify which port ID on your computer is the USB port is to run SP Loader first without the USB connection and read the list of available ports in SP Loader. After restoring the USB connection with the receiver, check that list again. An extra port ID will then be listed, being the one assigned to the USB port. Select that port. (You don't need to define a baud rate for a USB port.)

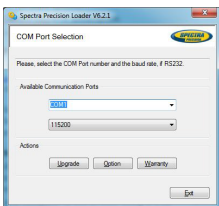

4. To upgrade receiver firmware, install a new firmware option or validate a CenterPoint RTX subscription, see sub-sections below.

Upgrading Receiver Firmware

You are not allowed to upgrade a receiver if anti-theft or/and start up protection is active or if the receiver is operated with an in-progress or expired validity period.

Firmware upgrades will be downloadable from the Spectra Precision website in the form of compressed “.tar” files. The name of the “.tar” file, as well as the step-by step upgrade procedure will be given in the accompanying *Release Note*. Completing a firmware upgrade procedure will take up to 10 minutes. For this reason, it must be run with the receiver powered from either a properly charged internal battery or using an external power source.

Unless otherwise specified in the *Release Note* attached to the upgrade package, follow the instructions below to complete the upgrade of your receiver:

1. Follow the first three steps described in *Getting Started With SP Loader on page 114*.
2. Click **Upgrade**. Wait until SP Loader has detected the receiver.
3. Browse your computer in search of the upgrade file.
4. Select the file and click **Open**. SP Loader then provides information on the currently installed firmware, the new firmware as well as the current state of the battery (if the internal battery is used).

This should tell you if you can run the upgrade with the battery, or rather use a fresh one or an external power supply.



5. When you are ready, click on the **Update** button.
6. Let the receiver proceed with the upgrade (a status window is displayed showing a progress bar). **Ensure the receiver is not turned off while installation is in progress.**
7. After successful completion of the upgrade, click **Close** to close the status window. Check that the new firmware is

now installed (version and date displayed in the SP Loader main window).

8. Click **Close** again, then **Exit** to quit SP Loader.

Installing a Firmware Option

Before you start this procedure, make sure you have received an email from Spectra Precision containing the *POP*N (Proof Of Purchase Number) corresponding to the firmware option you have purchased.

NOTE : Your computer needs an Internet connection to install a firmware option using a POPN.

With the POPN now in your possession, do the following to install a new firmware option:

- Follow the first three steps described in *Getting Started With SP Loader on page 114*.
- Click **Option**. Wait until SP Loader has detected the receiver.

SP Loader then displays the serial number of your receiver and prompts you to enter the POPN.

(There is an alternate method to activate a firmware option, which is to enter the option key (provided by Spectra Precision) corresponding to the desired firmware option, and to specify that option in the nearby field.)

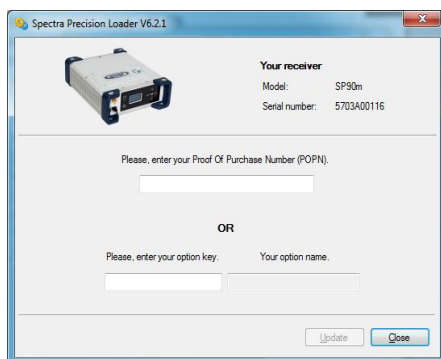

- Enter the POPN and then click on **Update**. Let the receiver proceed with the installation of the firmware option (a status window is displayed showing a progress bar). **Ensure the receiver is not turned off while installation is in progress.**
- After successful completion of the installation, click **Close** to close the status window.
- Click **Close** again, then **Exit** to quit SP Loader.

Activating a CenterPoint RTX Subscription

After you have purchased a CenterPoint RTX subscription, *Trimble Positioning Services* will email you an activation code.

Use the same procedure as the one used to install a firmware option (see *page 116*; the available RTX subscriptions are listed as firmware options). The only difference is that no POPN is provided for this procedure. Just enter the code provided by *Trimble Positioning Services* and specify the type of subscription you purchased before you click **Update**.

Reading Receiver Warranty Expiration Date

SP Loader can be used to query the Spectra Precision database for the warranty expiration date of your GNSS receiver. (After a receiver warranty has expired, remember receiver firmware upgrades are no longer free of charge.)

You don't need to have your receiver connected to *SP Loader* to read its warranty expiration date. Just enter its type and serial number and *SP Loader* will return this information to you, provided there is an active Internet connection on your computer, and your receiver is known to the database.

- Run *SP Loader* on your computer.
- Click on **Warranty**
- Select the type of your receiver and enter its serial number
- Click on **Compute**. *SP Loader* returns the warranty expiration date in a field underneath the **Compute** button.

Additionally, *SP Loader* generates a proprietary command that you can run in your receiver if you want to be sure your receiver has the correct warranty expiration date in memory. Carefully write down this command

Use **Terminal Window** in Survey Pro, or **GPS Utility** > **Send Command** in FAST Survey to apply this command to the receiver.

NOTE: When upgrading the receiver firmware using a computer with an Internet connection, be aware *SP Loader* will at the same time automatically check the warranty expiration date of your receiver. *SP Loader* will ask you if it can update this date if it is found wrong.

SP File Manager Software Utility

SP File Manager allows you to copy “log” files and G-files directly from the receiver’s internal memory to the desired folder on your office computer.

Additionally you can delete any G-file or “log” file from the receiver’s internal memory.

G-files are GNSS raw data files in proprietary format (ATOM). “Log” files are editable text files listing all the operations performed by the receiver in one day.

SP File Manager is available from the Spectra Precision website as an executable file (*SPFileManagerSetup.exe*) through the link below:

<http://www.spectraprecision.com/eng/sp90m.html#WUjSUdxLdhE>

(Click on the Support tab to access the download link.)

Installing SP File Manager

SP File Manager is very easy to install:

- Download the executable file from the Spectra Precision website (use above link).
- Double-click on the file to complete the installation.

Connecting SP90m to your Computer

SP File Manager will use either a serial (RS232), Bluetooth or USB connection to communicate with the receiver. USB is recommended.

Getting Started With SP File Manager

Double-click on . The *SP File Manager* window which then appears is detailed below.

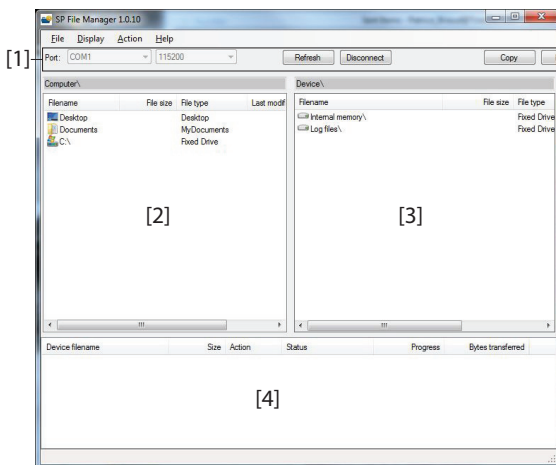

[1]: SP File Manager toolbar. This toolbar consists of the following items:

- **Port** and baud rate scroll-down lists: Let you choose which serial port is used on computer side for the connection with the receiver (baud rate only makes sense when an RS232 serial line is used). Use 115200 Bd to communicate with SP90m.
- **Connect** / Refresh button: **Connect** allows you to activate the connection between the computer and the receiver via the chosen serial line.

When the connection is established, the button is changed into **Refresh**, which allows you to update the content of the two *SP File Manager* panes ([2] and [3] described below)

- **Disconnect** button: Allows you to deactivate the connection currently established between the computer and the receiver.
- **Copy** button: Copies the file(s) selected in pane [3] to pane [2]. In pane [2], you have to open the folder where to copy to before clicking on the **Copy** button.
NOTE: Copied files have different creation dates and times compared to those of their respective original files. The new dates and times are those corresponding to when the files were copied.
- **Delete** button: Deletes the files currently selected in pane [2] or [3].

[2]: Pane showing the content of the currently open folder on computer side.

[3]: Pane showing the content of the currently open folder on receiver side. The receiver's root folder contains two to three sub-folders:

- **Internal memory**: Lists all G-files recorded by the receiver in its internal memory
- **Log files**: Contains log files (one per day). Each log file lists all the actions performed by the receiver in one day.
- **USB key**, if one is currently connected to the receiver.

To open a folder, double-click on it. To go back to the parent folder, click on .

[4]: Pane showing copy/delete operations in progress, and all those completed since the connection with the receiver was established. This pane is cleared at the beginning of each new working session of *SP File Manager*.

Establishing a Connection with the Receiver

- Set up the USB connection between the computer and receiver.
- Turn on the receiver.
- Launch *SP File Manager* on your computer. This opens the *SP File Manager* window.
- Select the right COM port (see also the Note in *Getting Started With SP Loader on page 114*) and then click on the **Connect** button.

As a result, the pane on the right-hand side of the window lists the two or three folders that can be seen on the receiver.

Copying Files to the Office Computer

- In the right-hand side of the window, double-click on the sub-folder containing the files you want to copy to the computer.

(If needed, click on  to go back to the parent folder and open another sub-folder.)

- In the left-hand side of the window, browse your computer to the folder where to copy the files (recipient folder).
- In the right-hand side of the window, highlight the file(s) you want to copy.
- Click on the **Copy** button. Files are then copied, as requested. The lower part of the screen provides reports information on the copy operations in progress.

Deleting Files from the Receiver

- In the right-hand side of the window, double-click on the sub-folder containing the files you want to delete from the receiver.

(If needed, click on  to go back to the parent folder and open another sub-folder.)

- Still in the right-hand side of the window, highlight the file(s) you want to delete.
- Click on the **Delete** button. Files are then deleted. The lower part of the screen provides reports information on the delete operations in progress.

UHF Networking

This feature allows a rover to receive corrections from up to three different bases broadcasting separately their corrections via radio, on the same frequency channel, but at different times so the rover can receive these corrections properly.

UHF networking can be implemented in SP90m provided you use Survey Pro as the field software.

UHF networking may be used in two different modes:

- **Manual:** The rover operator chooses which of the bases to work with. The bases will all be within range so the operator can change the base used at all times (see diagram below).

Typically, the manual mode is used when redundancy is required in terms of corrections availability within a working area. On the diagram below, the darker area represents the area where the rover can operate from any of the two bases.

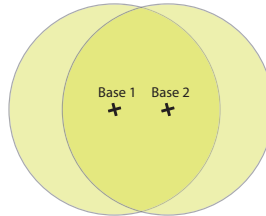

- **Automatic:** The rover will automatically switch to the base within range that provides the best quality of corrections. Typically the automatic mode is used when you need to extend the UHF radio coverage.

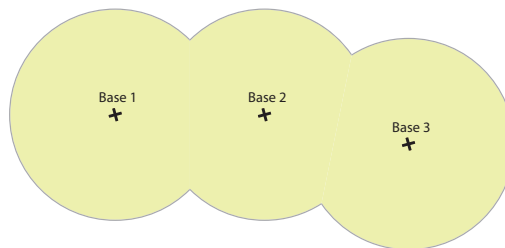

Implementing UHF networking on rover side consists of:

1. Activating this mode.
2. Choosing between automatic or manual selection of the base used. In Survey Pro, this setting is accessible from the **GNSS Status** function after you have started a survey. Selecting the manual mode means specifying the ID of the base you would like to work with.

NMEA Messages **ALR: Alarms**

\$PASHR,ALR,d1,d2,c3,s4,d5,s6*cc

Parameter	Description	Range
d1	Alarm code	0-255
d2	Alarm sub-code	0-255
c3	Stream ID reporting the alarm (if relevant, otherwise blank field): <ul style="list-style-type: none"> • A, B, F: Serial port • U: USB serial port • C, H, T: Bluetooth port • D: Internal radio • E: CSD modem • P, Q: TCP/IP client stream • I, J: TCP/IP client server • M: G-file 	A-F, H-J, M, P, Q, U
s4	Alarm category	BLUETOOTH, INPUT, MEMORY, MODEM, NETWORK, OTHER, POWER, PVT, RADIO, WIFI
d5	Alarm level: <ul style="list-style-type: none"> • 0: Low • 1: Medium • 2: High 	0-2
s6	Description	
*cc	Checksum	*00-*FF

ARA: True Heading

This message delivers either pitch- OR roll-related data (speed, accuracy), not both at the same time, depending on how the antennas are installed.

\$PASHR,ARA,f1,m2,f3,f4,f5,f6,f7,f8,f9*cc

Parameter	Description	Range
f1	"0" when message content is valid	
m2	Current UTC time of attitude fix (hhmmss.ss)	000000.00-235959.99
f3	Heading speed, in degrees/sec	"-": Turn bow left "+": Turn bow right
f4	Pitch speed, in degrees/sec	"-": Downwards "+": Upwards
f5	Roll speed, in degrees/sec	"-": To port (left) "+": To starboard (right)
f6	Heading RMS accuracy, in degrees	
f7	Pitch RMS accuracy, in degrees	
f8	Roll RMS accuracy, in degrees	
f9	(Empty)	
*cc	Checksum	*00-*FF

ARR: Vector & Accuracy

\$PASHR,ARR,d0,d1,d2,m3,f4,f5,f6,f7,f8,f9,f10,f11,f12,d13,d14,d15,d16*cc

Parameter	Description	Range
d0	Vector number	1, 2, 3
d1	Vector mode: <ul style="list-style-type: none"> • 0: Invalid baseline • 1: Differential • 2: RTK float • 3: RTK fixed • 5: Other (dead reckoning, bad accuracy, difference between standalone positions). Messages with d1=5 may further be masked if users only want proven vector estimates. 	0-3, 5
d2	Number of SVs used in baseline computation (L1 portion)	0-99
m3	UTC time (hhmmss.ss)	000000.00-235959.99
f4	Delta antenna position, ECEF 1st coordinate (in meters)	±99999.999
f5	Delta antenna position, ECEF 2nd coordinate (in meters)	±99999.999
f6	Delta antenna position, ECEF 3rd coordinate (in meters)	±9999.999
f7	1st coordinate of standard deviation	99.999
f8	2nd coordinate of standard deviation	99.999
f9	3rd coordinate of standard deviation	99.999
f10	1st/2nd coordinate correlation	±99.999999
f11	1st/3rd coordinate correlation	±99.999999
f12	2nd/3rd coordinate correlation	±99.999999
c13	Reference data ID	1, 2, port letter
d14	Vector coordinate frame ID: <ul style="list-style-type: none"> • 0: XYZ 	0
d15	Vector operation: <ul style="list-style-type: none"> • 0: Fixed mode (vector length is constrained) • 1: Calibration (vector length is being calibrated) • 2: Flex mode 	0-2
d16	Clock assumption: <ul style="list-style-type: none"> • 0: Clock is assumed to be different for the "head" and "tail" of the vector (see Comments below) • 1: Clock is assumed to be the same for the "head" and "tail" of the vector (see Comments below) 	
*cc	Checksum	*00-*FF

ATT: True Heading

This message delivers either pitch OR roll angles, not both at the same time, depending on how the antennas are installed.

\$PASHR,ATT,f1,f2,f3,f4,f5,f6,d7*cc

Parameter	Description	Range
f1	Week time in seconds.	000000.00-604799.99
f2	True heading angle in degrees.	000.00-359.99999
f3	Pitch angle in degrees.	±90.00000
f4	Roll angle in degrees.	±90.00000
f5	Carrier measurement RMS error, in meters.	Full range of real variables
f6	Baseline RMS error, in meters.	Full range of real variables
d7	Integer ambiguity is "Fixed" or "Float": <ul style="list-style-type: none">• 0: Fixed• >0: Float	0, >0
*cc	Checksum	*00-*FF

AVR: Time, Yaw, Tilt

\$PTNL,AVR,m1,f2,Yaw,f3,Tilt,,,f4,s5,f6,d7*cc

Parameter	Description	Range
m1	Current UTC time of vector fix (hhmmss.ss)	000000.00-235959.99
f2,Yaw	Yaw angle, in degrees.	
f3,Tilt	Tilt angle, in degrees.	
f4	Range, in meters	
d5	GNSS quality indicator: <ul style="list-style-type: none">• 0: Fix not available or invalid• 1: Autonomous GPS fix.• 2: Differential carrier phase solution RTK (float)• 3: Differential carrier phase solution RTK (fixed)• 4: Differential code-based solution	0-4
f6	PDOP	0-9.9
d7	Number of satellites used in solution	
*cc	Checksum	*00-*FF

BTS: Bluetooth Status

\$PASHR,BTS,C,d1,s2,s3,d4,H,d5,s6,s7,d8,T,d9,s10,s11,d12*cc

Parameter	Description	Range
C,d1	Port C: <ul style="list-style-type: none">• 0: Not connected• 1: A device is connected	0, 1
s2	Device name connected to port C	64 char. max.
s3	Device address connected to port C(xx:xx:xx:xx:xx:xx)	17 char.
d4	Bluetooth link quality for the port C connection	0-100
H,d5	Port H: <ul style="list-style-type: none">• 0: Not connected• 1: A device is connected	0, 1
s6	Device name connected to port H	64 char. max.
s7	Device address connected to port H(xx:xx:xx:xx:xx:xx)	17 char.
d8	Bluetooth link quality for the port H connection	0-100
T,d9	Port T: <ul style="list-style-type: none">• 0: Not connected• 1: A device is connected	0, 1
s10	Device name connected to port T	64 char. max.
s11	Device address connected to port T(xx:xx:xx:xx:xx:xx)	17 char.
d12	Bluetooth link quality for the port T connection	0-100
*cc	Checksum	*00-*FF

CAP: Parameters of Antenna Used at Received Base

\$PASHR,CAP,s1,f2,f3,f4,f5,f6,f7*cc

Parameter	Description
s1	Antenna name, "NONE" if no name received for the base antenna.
f2	L1 North offset, in mm
f3	L1 East offset, in mm
f4	L1 Up offset, in mm
f5	L2 North offset, in mm
f6	L2 East offset, in mm
f7	L2 Up offset, in mm
*cc	Checksum

CPA: Height of Antenna Used at Received Base

\$PASHR,CPA,f1,f2,f3,m4,f5*cc

Parameter	Description	Range
f1	Antenna height, in meters. This field remains empty as long as no antenna height has been received.	0-99.999
f2	Antenna radius, in meters	0-9.9999
f3	Vertical offset, in meters	0-99.999
m4	Horizontal azimuth, in degrees, minutes (dddmm.mm)	0-35959.99
f5	Horizontal distance, in meters	0-99.999
f2, f3, m4, f5	Not applicable, all empty fields	-
*cc	Checksum	*00-*FF

CPO: Position of Received Base

\$PASHR,CPO,m1,c2,m3,c4,f5*cc

Parameter	Description	Range
m1	Latitude in degrees and minutes with 7 decimal places (ddmm.mmmmmmm)	0-90
c2	North (N) or South (S)	N, S
m3	Longitude in degrees, minutes with 7 decimal places (dddmm.mmmmmmm)	0-180
c4	West (W) or East (E)	W, E
f5	Height in meters	±99999.999
*cc	Checksum	*00-*FF

DDM: Differential Decoder Message

\$PASHR,DDM,c1,s2,s3,d4,s5,f6,f7,s8*cc

Parameter	Description	Range
c1	Port receiving corrections	A-E, I, P, Q, Z
s2	Message transport	RT2, RT3, CMR, CMX or ATM
s3	Message number/identifier	e.g. 1004 for RT3, RNX for ATM, etc.
d4	Counter of decoded messages	0-9999
s5	Base ID	
f6	Time tag, in seconds, as read from the decoded message	
f7	Age of corrections, in seconds	
s8	Attribute	60 characters max.
*cc	Checksum	*00-*FF

DDS: Differential Decoder Status

\$PASHR,DDS,d1,m2,d3,c4,s5,c6,d7,d8,d9,d10,d11,f12,f13,d14,n(d15,f16,f17)*cc

Parameter	Description	Range
d1	Differential decoder number. "1" corresponds to first decoder, etc. An empty field means the decoder used is not known.	1-4
m2	GNSS (output) time tag	000000.00-235959.99
d3	Number of decoded messages since last stream change	0-127
c4	ID of port from which corrections are received	A-E, I, P, Q, Z
s5	Protocol detected (empty means "no data")	RT2, RT3, CMR, ATM, CMX
d6	Time window, in seconds: <ul style="list-style-type: none"> • "0" if not defined or just initialized • "200" means equal to or greater than 200 	0-200
d7	Percentage of estimated overall data link quality/availability. Empty if not defined.	0-100
d8	Percentage of deselected information. Empty if not defined.	0-100
d9	CRC percentage. Empty if not defined.	0-100
d10	Standard of latency, in milliseconds	0-16383
d11	Mean latency, in milliseconds	0-16383
f12	Mean epoch interval, in seconds	0.00-3600
f13	Min. epoch interval, in seconds	0.00-3600
d14	Number (n) of different messages detected since last stream change	0-63
d15	Message type	RT2: 1-63 RT3: 1001-4094 CMR: 0(obs), 1(loc), 2(desc), 3(glo), 12(cmr+), 20 (glo encrypted) ATM: 0-15 CMX: no message reported
f16	Interval of last message, in seconds	0.000-1023.000
f17	Age of last message, in seconds	0.000-1023.000
*cc	Checksum	

DTM: Datum Reference

\$GPDTM,s1,,f2,c3,f4,c5,f6,s7*cc

Parameter	Description	Range
s1	Local datum code: <ul style="list-style-type: none"> W84: WGS84 used as local datum 999: Local datum computed using the parameters provided by the RTCM3.1 data stream. 	W84, 999
f2	Latitude offset, in meters	0-59.999999
c3	Direction of latitude	N, S
f4	Longitude offset, in meters	0-59.999999
c5	Direction of longitude	E, W
f6	Altitude offset, in meters	±0-99.999
s7	Reference datum code	W84
*cc	Checksum	*00-*FF

GBS: GNSS Satellite Fault Detection

\$--GBS,m1,f2,f3,f4,d5,f6,f7,f8,h9,h10*cc

Parameter	Description	Range
m1	UTC time of the GGA or GNS fix associated with this message (hhmmss.ss)	000000.00-235959.99
f2	Expected error in latitude, in meters, due to bias, with noise= 0	0.0-99.9
f3	Expected error in longitude, in meters, due to bias, with noise= 0	0.0-99.9
f4	Expected error in altitude, in meters, due to bias, with noise= 0	0.0-99.9
d5	ID number of most likely failed satellite	1-32 for GPS 33-64 for SBAS 65-96 for GLONASS 97-128 for Galileo 129-160 for BeiDou 193-202 for QZSS
f6	Probability of missed detection for most likely failed satellite	0.00-1.00
f7	Estimate of bias, in meters, on most likely failed satellite	0.0-99.9
f8	Standard deviation of bias estimate	0.0-99.9
h9	GNSS system ID	0-F
h10	GNSS signal ID	0-F
*cc	Checksum	*00-*FF

GGA: GNSS Position Message

\$GPGGA,m1,m2,c3,m4,c5,d6,d7,f8,f9,M,f10,M,f11,d12*cc

Parameter	Description	Range
m1	Current UTC time of position (hhmmss.ss)	000000.00-235959.99
m2	Latitude of position (ddmm.mmmmm)	0-90 0-59.999999
c3	Direction of latitude	N, S
m4	Longitude of position (dddmm.mmmmm)	0-180 0-59.999999
c5	Direction of longitude	E,W
d6	Position type: <ul style="list-style-type: none">• 0: Position not available or invalid• 1: Autonomous position• 2: RTCM Differential (or SBAS Differential)• 3: Not used• 4: RTK fixed• 5: RTK float• 6: Estimated (dead reckoning) mode	0-6
d7	Number of GNSS Satellites being used in the position computation	3-26
f8	HDOP	0-99.9
f9,M	Altitude, in meters, above mean seal level. "M" for meters	± 99999.999,M
f10,M	Geoidal separation in meters. "M" for meters.	± 999.999,M
f11	Age of differential corrections, in seconds	0-600999
d12	Base station ID	0-4095
*cc	Checksum	*00-*FF

GGK : GNSS Position Message

See Trimble documentation.

GGKX: GNSS Position Message

\$PTNL,GGKx,m1,m2,m3,c4,m5,c6,d7,d8,f9,f10,M,d11,f12,f13,f14,f15*cc

Parameter	Description	Range
m1	Current UTC time of position (hhmmss.ss)	000000.00-235959.99
m2	UTC date of position (mmddyy)	010101-123199
m3	Latitude of position (ddmm.mmmmmm)	0-90 0-59.999999
c4	Direction of latitude	N, S
m5	Longitude of position (dddmm.mmmmmm)	0-180 0-59.999999
c6	Direction of longitude	E,W
d7	Position type: <ul style="list-style-type: none"> • 0: Position not available or invalid • 1: Autonomous GPS fix • 2: RTK float solution or RTK location status • 3: RTK fix solution • 4: Differential, code phase only solution • 5: SBAS solution • 6: 3D network solution for RTK float or RTK location • 7: RTK fixed 3D network solution • 8: 2D network solution for RTK float or RTK location • 9: RTK fixed 2D network solution • 10: OmniSTAR HP/XP solution • 11: OmniSTAR VBS solution • 12: RTK location • 13: Beacon DGPS • 14: RTK Global 	0-14
d8	Number of GNSS Satellites being used in the position computation	3-26
f9	PDOP	0-99.9
f10,M	Ellipsoid height of fix (antenna height above ellipsoid. "M" for meters.	± 99999.999,M
d11	Number of extension fields to follow.	
f12	Sigma East	0.000-999.999
f13	Sigma North	0.000-999.999
f14	Sigma Up	0.000-999.999
f15	Propagation age	
*cc	Checksum	*00-*FF

GLL: Geographic Position - Latitude/Longitude

\$GPGLL,m1,c2,m3,c4,m5,c6,c7*cc

Parameter	Description	Range
m1	Latitude of position (ddmm.mmmmmm)	0-90 0-59.999999
c2	Direction of latitude	N, S
m3	Longitude of position (dddmm.mmmmmm)	0-180 0-59.999999
c4	Direction of longitude	E,W
m5	Current UTC time of position (hhmmss.ss)	000000.00- 235959.99
c6	Status <ul style="list-style-type: none">• A: Data valid• V: Data not valid	A, V
c7	Mode indicator: <ul style="list-style-type: none">• A: Autonomous mode• D: Differential mode• N: Data not valid• E: Estimated (dead reckoning) mode	A, D, N, E
*cc	Checksum	*00-*FF

GMP: GNSS Map Projection Fix Data

\$--GMP,m1,s2,s3,f4,f5,s6,d7,f8,f9,f10,f11,d12*cc

Parameter	Description	Range
"\$--GMP" Header	\$GPGMP: Only GPS satellites are used. \$GLGMP: Only GLONASS satellites are used. \$NGGMP: Several constellations (GPS, SBAS, GLONASS) are used.	\$GPGMP, \$GLGMP, \$NGGMP
m1	Current UTC time of position (hhmmss.ss)	000000.00- 235959.99
s2	Map projection identification: • LOC: Local coordinate system • Empty if no local coordinate system	LOC
s3	Map zone (empty)	
f4	X (Northern) component of grid (or local) coordinate, in meters	±999999999.999
f5	Y (Eastern) component of grid (or local) coordinate, in meters	±999999999.999
s6	Mode indicator: • N: No fix • A: Autonomous • D: Differential • R: Fixed RTK • F: Float RTK	N, A, D, R, F
d7	Number of GNSS Satellites being used in the position computation	3-26
f8	HDOP	0-99.9
f9	Altitude above mean seal level, or local altitude, in meters.	± 99999.999,M
f10	Geoidal separation in meters.	± 999.999,M
f11	Age of differential corrections, in seconds	0-999.9
d12	Base station ID	0-4095
*cc	Checksum	*00-*FF

GNS: GNSS Fix Data

\$--GNS,m1,m2,c3,m4,c5,s6,d7,f8,f9,f10,f11,d12*cc

Parameter	Description	Range
m1	Current UTC time of position (hhmmss.ss)	000000.00-235959.99
m2	Latitude of position (ddmm.mmmmmm)	0-90 0-59.999999
c3	Direction of latitude	N, S
m4	Longitude of position (dddmm.mmmmmm)	0-180 0-59.999999
c5	Direction of longitude	E, W
s6	Mode indicator (1 character by constellation): <ul style="list-style-type: none">• N: No fix• A: Autonomous position• D: Differential• R: RTK Fixed• F: RTK Float	N, A, D, R, F
d7	Number of GNSS satellites being used in the position computation.	3-26
f8	HDOP	0-99.9
f9	Altitude above mean sea level.	±99999.999
f10	Geoidal separation, in meters	±999.999
f11	Age of differential corrections, in s	0-999
d12	Base station ID (RTCM only)	0-4095
*cc	Checksum	

GRS: GNSS Range Residuals

\$--GRS,m1,d2,n(f3)*cc

Parameter	Description	Range
"\$--GRS" Header	\$GPGRS: Only GPS satellites are used. \$GLGRS: Only GLONASS satellites are used. \$NGRS: Several constellations (GPS, SBAS, GLONASS) are used. \$GBGRS: Only BeiDou satellites are used. \$NGRS: Several constellations are used (GPS, SBAS, GLONASS, QZSS, BeiDou)	\$GPGRS \$GLGRS \$GBGRS \$NGRS
m1	Current UTC time of GGA position (hhmmss.ss)	000000.00-235959.99
d2	Mode used to compute range residuals	Always "1"
f3	Range residual for satellite used in position computation (repeated "n" times, where n is the number of satellites used in position computation). Residuals are listed in the same order as the satellites in the GSA message so that each residual provided can easily be associated with the right satellite.	±999.999
*cc	Checksum	*00-*FF

GSA: GNSS DOP and Active Satellites

\$--GSA,c1,d2,d3,d4,d5,d6,d7,d8,d9,d10,d11,d12,d13,d14,f15,f16,f17*cc

Parameter	Description	Range
"\$--GSA" Header	\$GPGSA: Only GPS satellites are used. \$GLGSA: Only GLONASS sats are used. \$GBGSA: Only BEIDOU sats are used \$NGGSA: Several constellations (GPS, SBAS, GLONASS, BEIDOU) are used.	\$GPGSA, \$GLGSA, \$GBGSA, \$NGGSA
c1	Output mode: • M: Manual • A: Automatic	M, A
d2	Position indicator: • 1: No position available • 2: 2D position • 3: 3D position	1-3
d3-d14	Satellites used in the position solution (blank fields for unused channels)	GPS: 1-32 GLONASS: 65-96 SBAS: 1-44 GALILEO: 1-30 QZSS: 1-5 BEIDOU: 1-35 IRNSS: 1-7
f15	PDOP	0-9.9
f16	HDOP	0-9.9
f17	VDOP	0-9.9
*cc	Checksum	*00-*FF

GST: GNSS Pseudo-range Error Statistics

\$--GST,m1,f2,f3,f4,f5,f6,f7,f8*cc

Parameter	Description	Range
"\$--GST" Header	\$GPGST: Only GPS satellites are used. \$GLGST: Only GLONASS satellites are used. \$GNGST: Several constellations (GPS, SBAS, GLONASS, BEIDOU) are used.	\$GPGST, \$GLGST, \$GNGST
m1	Current UTC time of position (hhmmss.ss)	000000.00- 235959.99
f2	RMS value of standard deviation of range inputs (DGNS corrections included), in meters	0.000-999.999
f3	Standard deviation of semi-major axis of error ellipse, in meters	0.000-999.999
f4	Standard deviation of semi-minor axis of error ellipse, in meters	0.000-999.999
f5	Orientation of semi-major axis of error ellipse, in degrees from true North	0 to 180
f6	Standard deviation of latitude error, in meters	0.000-999.999
f7	Standard deviation of longitude error, in meters	0.000-999.999
f8	Standard deviation of altitude error, in meters	0.000-999.999
*cc	Checksum	*00-*FF

GSV: GNSS Satellites in View

\$--GSV,d1,d2,d3,n(d4,d5,d6,f7),h8*cc

Parameter	Description	Range
"\$--GSV" Header	\$GPGSV: GPS satellites. \$GLGSV: GLONASS satellites \$GAGSV: GALILEO satellites \$GSGSV: SBAS satellites (including QZSS L1 SAIF) \$GQGSV: QZSS satellites \$GBGSV: BeiDou satellites \$GIGSV: IRNSS satellites	\$GPGSV, \$GLGSV \$GAGSV \$GSGSV \$GQGSV \$GBGSV \$GIGSV
d1	Total number of messages	1-4
d2	Message number	1-4
d3	Total number of satellites in view	0-16
d4	Satellite PRN	GPS: 1-32 GLONASS: 65-96 SBAS: 1-44 GALILEO: 1-30 QZSS: 1-5 BEIDOU: 1-35 IRNSS: 1-7
d5	Elevation in degrees	0-90
d6	Azimuth in degrees	0-359
f7	SNR in dB.Hz	30.0-60.0
h8	Signal ID	0-F
*cc	Checksum	*00-*FF

HDT: True Heading

\$GPHDT,f1,T*cc

Parameter	Description	Range
f1,T	Last computed heading value, in degrees "T" for "True".	0-359.99
*cc	Checksum	*00-*FF

HPR: True Heading

This message delivers either pitch OR roll angles, not both at the same time, depending on how the antennas are installed.

\$PASHR,HPR,m1,f2,f3,f4,f5,f6,d7,d8,d9,f10*cc

Parameter	Description	Range
m1	UTC time of attitude data (hhmmss.ss).	000000.00-235959.99
f2	True heading angle in degrees.	000.00-359.99999
f3	Pitch angle in degrees.	±90.00000
f4	Roll angle in degrees.	±90.00000
f5	Carrier measurement RMS error, in meters.	Full range of real variables
f6	Baseline RMS error, in meters. (=0 if baseline is not constrained)	Full range of real variables
d7	Integer ambiguity: • 0: Fixed • >0: Float	0, >0
d8	Attitude/heading mode status: • 0: Operation with fixed baseline length • 1: Calibration in progress • 2: Flex (flexible) baseline mode ON	0, 1, 2
d9	Character string of the type "y.xxx" defined as follows: • "y" refers to the antenna setup: y=0: no length constraint is applied y=1: heading mode (one vector) y=2: attitude mode (2 vectors) y=3: attitude mode with 3 or more vectors • Each "x" (0 to 9) represents the number of Double Differences (DD) used in the corresponding baseline. If this number is greater than 9, then "9" is reported. If there are only 2 vectors, the last x is "0" Double differences refer to the very last integer second time-tagged epoch.	y.xxx
f10	PDOP corresponding to vector V12, as computed for the very last integer second (time-tagged epoch). Empty if PDOP unknown.	
*cc	Checksum	*00-*FF

LTN: Latency

\$PASHR,LTN,d1*cc

Parameter	Description	Range
d1	Latency in milliseconds.	
*cc	Optional checksum	*00-*FF

MDM: Modem State and Parameter

\$PASHR,MDM,c1,d2,s3,PWR=s4,PIN=s5,PTC=d6,CBS=d7,APN=s8,LGN=s9,PWD=s10,PHN=s11,ADL=c12,RNO=d13,MOD=s14,NET=d15,ANT=s16*cc

Parameter	Description	Range
c1	Modem port	E
d2	Modem baud rate	9
s3	Modem state. "NONE" means that MODEM option [Z] is not valid.	OFF, ON, INIT, DIALING, ONLINE, NONE
PWR=s4	Power mode: <ul style="list-style-type: none">AUT: AutomaticMAN: Manual	AUT, MAN
PIN=s5	PIN code	4-8 digits
PTC=d6	Protocol: <ul style="list-style-type: none">0: CSD1: GPRS	0-1
CBS=d7	Not used CSD mode: <ul style="list-style-type: none">0: V.32 9600 bauds1: V.110 9600 bauds ISDN	0-1
APN=s8	Access Point Name (GPRS)	32 char. max.
LGN=s9	Login (GPRS)	32 char. max.
PWD=s10	Password (GPRS)	32 char. max.
PHN=s11	Phone number (CSD)	20 digits max.
ADL=c12	Auto-dial mode	Y, N
RNO=d13	Maximum number of re-dials (CSD)	0-15
MOD=s14	Modem model (empty if unknown)	Centurion PHS8
NET=d15	2G/3G selection mode: <ul style="list-style-type: none">0: Automatic (2G or 3G)Forced to operate in 2G	0-1
ANT=S16	GSM antenna used: <ul style="list-style-type: none">INT: InternalEXT: External	INT, EXT
*cc	Checksum	*00-*FF

POS: Position

\$PASHR,POS,d1,d2,m3,m4,c5,m6,c7,f8,f9,f10,f11,f12,f13,f14,f15,f16,d17*cc

Parameter	Description	Range
d1	Flag describing position solution type: <ul style="list-style-type: none"> • 0: Autonomous position • 1: RTCM code differential (or SBAS/BDS differential) • 2: RTK float (or RTX) • 3: RTK fixed (or RTX) • 5: Estimated (dead-reckoning) mode • 9: SBAS differential • 10: BeiDou Differential • 12: RTK float • 13: RTK fixed • 22: RTK Float Dithered • 23: RTK Fixed, Dithered 	0-3, 5, 9-10, 12-13, 22-23
d2	Count of satellites used in position computation	0-26
m3	Current UTC time of position (hhmmss.ss)	000000.00- 235959.99
m4	Latitude of position (ddmm.mmmmm)	0-90° 00-59.999999 minutes
c5	North (N) or South (S)	N, S
m6	Longitude of position (dddmm.mmmmm)	0-180° 00--59.999999 minutes
c7	East (E) or West (W)	E, W
f8	Altitude above the WGS84 ellipsoid	±9999.000
f9	Age of differential corrections (seconds)	0-999.9
f10	True Track/Course Over Ground, in degrees	0.0-359.9
f11	Speed Over Ground, in knots	0.0-999.999
f12	Vertical velocity in m/s	±999.999
f13	PDOP	0-99.9
f14	HDOP	0-99.9
f15	VDOP	0-99.9
f16	TDOP	0-99.9
d17	Base station ID	0-4095
*cc	Checksum	*00-*FF

PTT: PPS Time Tag

\$PASHR,PTT,d1,m2*cc

Parameter	Description	Range
d1	Day of week: <ul style="list-style-type: none">• 1: Sunday• 7: Saturday	1-7
m2	GPS time tag in hours, minutes, seconds	0-23:59:59.9999999
*cc	Checksum	*00-*FF

PWR: Power Status

\$PASHR,PWR,d1,[f2],[f3],[d4],[d5],[f6],[d7],[d8],d9,[d10]*cc

Parameter	Description	Range
d1	Power source: <ul style="list-style-type: none">• 0: Internal battery• 1: External battery• 2: External DC source	0-2
f2	Output voltage of battery (internal), in volts	0.0-12.0
f3	Empty	
d4	Percentage of remaining battery energy	0-100
d5	Empty	
f6	DC input voltage from external power, in volts	0.0-30.0
d7	Battery charging status: <ul style="list-style-type: none">• 0: Charging• 1: Discharging• 2: Fully charged• 3: Fully discharged	0-3
d8	Empty	
d9	Internal temperature, in degrees C	
d10	Battery temperature, in degrees C	
*cc	Checksum	*00-*FF

RCS: Recording Status

\$PASHR,RCS,c1,d2,s3,d4,f5,f6,f7,d8,d9)*cc

Parameter	Description	Range
c1	Recording status: <ul style="list-style-type: none"> • Y: Data recording in progress; receiver will keep on recording data after a power cycle. • N: No data recording in progress; after a power cycle, no recording will start either. • S: No data recording in progress, but receiver will start recording data after a power cycle. • R: Data recording in progress, but receiver will stop recording data after a power cycle. 	Y, N, S, R
d2	Memory where data file is recorded: <ul style="list-style-type: none"> • 0: Internal memory 	
s3	Data filename	255 char. max.
d4	Recording rate, in seconds:	0.05-960
f5	Occupation type: <ul style="list-style-type: none"> • 0: Static • 1: Quasi-static • 2: Dynamic 	0-2
d6	Occupation state: <ul style="list-style-type: none"> • 0: In progress • 1: No occupation 	0-1
s7	Occupation name	255 char. max.
*cc	Checksum	*00-*FF

RMC: Recommended Minimum Specific GNSS Data

\$GPRMC,m1,c2,m3,c4,m5,c6,f7,f8,d9,f10,c11,c12*cc

Parameter	Description	Range
m1	Current UTC time of position (hhmmss.ss)	000000.00-235959.99
c2	Status <ul style="list-style-type: none">• A: Data valid• V:	A, V
m3	Latitude of position (ddmm.mmmmm)	0-90 0-59.999999
c4	Direction of latitude	N, S
m5	Longitude of position (dddmm.mmmmm)	0-180 0-59.999999
c6	Direction of longitude	E,W
f7	Speed Over Ground, in knots	000.0-999.9
f8	Course Over Ground, in degrees (true)	000.0-359.9
d9	Date (ddmmyy)	010100-311299
f10	Magnetic variation, in degrees	0.00-99.9
c11	Direction of variation	E, W
c12	Mode indicator: <ul style="list-style-type: none">• A: Autonomous mode• D: Differential mode• N: Data not valid	A, D, N
*cc	Checksum	*00-*FF

SBD: BEIDOU Satellites Status

\$PASHR,SBD,d1,n(d2,d3,d4,f5,f6,f7,c8,c9)*cc

Parameter	Description	Range
d1	Number of visible satellites	0-37
d2	Satellite PRN number	1-37
d3	Satellite azimuth, in degrees	0-359
d4	Satellite elevation, in degrees	0-90
f5	Satellite B1 signal/noise in dB.Hz	0.0-60.0
f6	Satellite B2 signal/noise in dB.Hz	0.0-60.0
f7	Satellite B3 signal/noise in dB.Hz	0.0-60.0
c8	Satellite usage status	
c9	Satellite correcting status	
*cc	Checksum	*00-*FF

SGA: GALILEO Satellites Status (E1,E5a,E5b)

\$PASHR,SGA,d1,n(d2,d3,d4,f5,,f7,c8,c9)*cc

Parameter	Description	Range
d1	Number of visible satellites	0-36
d2	SV PRN number	1-36
d3	SV azimuth in degrees	0-359
d4	SV elevation angle in degrees	0-90
f5	SV E1 signal/noise in dB.Hz	0.0-60.0
f6	SV E5b signal/noise in dB.Hz	0.0-60.0
f7	SV E5a signal/noise in dB.Hz	0.0-60.0
c8	Satellite usage status	
c9	Satellite correcting status	
*cc	Checksum	*00-*FF

SSL: GLONASS Satellites Status

\$PASHR,SGL,d1,n(d2,d3,d4,f5,f6,f7,c8,c9)*cc

Parameter	Description	Range
d1	Number of visible satellites	0-24
d2	SV PRN number	1-24
d3	SV azimuth in degrees	0-359
d4	SV elevation angle in degrees	0-90
f5	SV L1 signal/noise in dB.Hz	0.0-60.0
f6	SV L2 signal/noise in dB.Hz	0.0-60.0
f7	SV L3 signal/noise in dB.Hz	0.0-60.0
c8	Satellite usage status	
c9	Satellite correcting status	
*cc	Checksum	*00-*FF

SGO: GALILEO Satellites Status (E1,E5a,E5b,E6)

\$PASHR,SGO,d1,n(d2,d3,d4,f5,f6,f7,f8,f9,c10,c11)*cc

Parameter	Description	Range
d1	Number of visible satellites	0-36
d2	SV PRN number	1-36
d3	SV azimuth in degrees	0-359
d4	SV elevation angle in degrees	0-90
f5	SV E1 signal/noise in dB.Hz	0.0-60.0
f6	SV E5b signal/noise in dB.Hz	0.0-60.0
f7	SV E5a signal/noise in dB.Hz	0.0-60.0
f8	SV E6 signal/noise in dB.Hz	0.0-60.0
f9	Empty	
c10	Satellite usage status	
c11	Satellite correcting status	
*cc	Checksum	*00-*FF

SGP: GPS Satellites Status

\$PASHR,SGP,d1,n(d2,d3,d4,f5,f6,f7,c8,c9)*cc

Parameter	Description	Range
d1	Number of visible satellites	0-63
d2	SV PRN number	1-63
d3	SV azimuth in degrees	0-359
d4	SV elevation angle in degrees	0-90
f5	SV L1 signal/noise in dB.Hz	0.0-60.0
f6	SV L2 signal/noise in dB.Hz	0.0-60.0
f7	SV L5 signal/noise in dB.Hz	0.0-60.0
c8	Satellite usage status	
c9	Satellite correcting status below)	
*cc	Checksum	*00-*FF

SIR: IRNSS Satellites Status

\$PASHR,SIR,d1,n(d2,d3,d4,f5,f6,f7,c8,c9)*cc

Parameter	Description	Range
d1	Number of visible satellites	0-7
d2	SV PRN number	1-7
d3	SV azimuth in degrees	0-359
d4	SV elevation angle in degrees	0-90
f5	Empty	
f6	Empty	
f7	SV L5 signal/noise in dB.Hz	0.0-60.0
c8	Satellite usage status	
c9	Satellite correcting status below)	
*cc	Checksum	*00-*FF

SLB: L-Band Satellites Status

\$PASHR,SLB,d1,n(d2,d3,d4,d5,f6)*cc

Parameter	Description	Range
d1	Number of visible satellites	0-11
d2	L-Band satellite number	01-07, 08-11
d3	Continuous tracking interval, in seconds	
d4	SV azimuth angle, in degrees	0-359
d5	SV elevation angle, in degrees	0-90
f6	SV signal/noise in dB.Hz	0.0-60.0
*cc	Checksum	*00-*FF

SQZ: QZSS Satellites Status

\$PASHR,SQZ,d1,n(d2,d3,d4,f5,f6,f7,c8,c9)*cc

Parameter	Description	Range
d1	Number of visible satellites	0-5
d2	SV PRN number	1-5
d3	SV azimuth in degrees	0-359
d4	SV elevation angle in degrees	0-90
f5	SV L1 signal/noise in dB.Hz	0.0-60.0
f6	SV L2 signal/noise in dB.Hz	0.0-60.0
f7	SV L5 signal/noise in dB.Hz	0.0-60.0
c8	Satellite usage status	
c9	Satellite correcting status	
*cc	Checksum	*00-*FF

SSB: SBAS Satellites Status

\$PASHR,SSB,d1,n(d2,d3,d4,f5,f6,f7,c8,c9)*cc

Parameter	Description	Range
d1	Number of visible satellites	1-44
d2	SV PRN number	1-39, 40-44
d3	SV azimuth in degrees	0-359
d4	SV elevation angle in degrees	0-90
f5	SV L1 signal/noise in dB.Hz	0.0-60.0
f6	Empty field	
f7	SV L5 signal/noise in dB.Hz	0.0-60.0
c8	Satellite usage status	
c9	Satellite correcting status	
*cc	Checksum	*00-*FF

TEM: Receiver Temperature

\$PASHR,TEM,s1*cc

Parameter	Description	Range
d1	Receiver internal temperature, in thousandths of degrees	
*cc	Checksum	*00-*FF

THS: True Heading and Status

\$PASHR,TEM,f1,c2*cc

Parameter	Description	Range
f1	Last computed heading value, in degrees (true).	000.00-359.99
c2	Solution status: <ul style="list-style-type: none">• A: Autonomous• E: Estimated (dead reckoning)• M: Manual input• S: Simulator• V: Data not valid (including standby)	A, E, M, S, V
*cc	Checksum	*00-*FF

TTT: Event Marker

\$PASHR,TTT,d1,m2*cc

Parameter	Description	Range
d1	Day of week: <ul style="list-style-type: none">• 1: Sunday• 7: Saturday	1-7
m2	GPS time tag in hours, minutes, seconds	0-23:59:59.9999999
*cc	Optional checksum	*00-*FF

VCR: Vector and Accuracy

\$PASHR,VCR,d0,c1,d2,m3,f4,f5,f6,f7,f8,f9,f10,f11,f12,d13,c14*cc

Parameter	Description	Range
d0	Baseline number (see \$PASHS,BRV)	1, 2, 3
c1	Baseline mode: <ul style="list-style-type: none"> • 0: Invalid baseline • 1: Differential • 2: RTK float • 3: RTK fixed • 5: Other 	0-3, 5
d2	Number of SVs used in baseline computation (L1 portion)	0-99
m3	UTC time (hhmmss.ss)	000000.00-235959.99
f4	First coordinate of delta antenna position, ECEF, in meters	±99999.999
f5	Second coordinate of delta antenna position, ECEF, in meters	±99999.999
f6	Third coordinate of delta antenna position, ECEF, in meters	±9999.999
f7	Standard deviation, first coordinate	99.999
f8	Standard deviation, second coordinate	99.999
f9	Standard deviation, third coordinate	99.999
f10	Correlation (half)	±9.999999
f11	Correlation (one third)	±9.999999
f12	Correlation (two third)	±9.999999
d13	Base station ID (same as GGA)	0-4095
c14	Baseline coordinate frame ID: <ul style="list-style-type: none"> • 0: XYZ 	0
*cc	Checksum	*00-*FF

VCT: Vector and Accuracy

\$PASHR,VCT,c1,d2,m3,f4,f5,f6,f7,f8,f9,f10,f11,f12,d13,d14,d15,d16,d17*cc

Parameter	Description	Range
c1	Baseline mode: <ul style="list-style-type: none"> • 0: Invalid baseline • 1: Differential • 2: RTK float • 3: RTK fixed • 5: Other 	0-3, 5
d2	Number of SVs used in position computation	3-26
m3	UTC time (hmmss.ss)	000000.00-235959.99
f4	Delta antenna position, ECEF X coordinate (in meters)	±99999.999
f5	Delta antenna position, ECEF Y coordinate (in meters)	±99999.999
f6	Delta antenna position, ECEF Z coordinate (in meters)	±9999.999
f7	Standard deviation X coordinate (latitude)	99.999
f8	Standard deviation Y coordinate (longitude)	99.999
f9	Standard deviation Z coordinate (height)	99.999
f10	Correlation XY	±9.999999
f11	Correlation XZ	±9.999999
f12	Correlation YZ	±9.999999
d13	Base station ID (same as in GGA)	0-4095
d14	Baseline coordinate frame ID: <ul style="list-style-type: none"> • 0: XYZ 	0
d15	Baseline number	1-3
d16	VRS: <ul style="list-style-type: none"> • 0: Physical • 1: Virtual • Empty: Not known 	Empty, 0, 1
d17	Static mode assumption: <ul style="list-style-type: none"> • 0: Static • 1: Moving • Empty: Not known 	Empty, 0, 1
*cc	Checksum	*00-*FF

VEL: Velocity

\$PASHR,VEL,f1,m2,f3,f4,f5,f6,f7,f8,d9*cc

Parameter	Description	Range
f1	Reserved	1
m2	Current UTC time of velocity fix (hhmmss.ss)	
f3	Easting velocity, in m/s	
f4	Northing velocity, in m/s	
f5	Vertical velocity, in m/s	
f6	Easting velocity RMS error, in mm/s	
f7	Northing velocity RMS error, in mm/s	
f8	Vertical velocity RMS error, in mm/s	
d9	Applied effective velocity smoothing interval, in ms (empty if unknown)	
*cc	Checksum	*00-*FF

VTG: Course Over Ground and Ground Speed

\$GPVTG,f1,T,f2,M,f3,N,f4,K,c5*cc

Parameter	Description	Range
f1,T	COG (with respect to True North) T for "True" North: COG orientation	000.00-359.99
f2,M	COG (with respect to Magnetic North) M for "Magnetic" North: COG orientation	000.00-359.99
f3,N	SOG (Speed Over Ground) N for "knots": SOG unit	000.00-999.999
f4,K	SOG (Speed Over Ground) K for "km/hr": SOG unit	000.00-999.999
c5	Mode indicator: <ul style="list-style-type: none">A: Autonomous modeD: Differential modeN: Data not valid	A, D, N
*cc	Checksum	*00-*FF

ZDA: Date & Time

\$GPZDA,ZDA,m1,d2,d3,d4,d5,d6*cc

Parameter	Description	Range
m1	UTC time (hhmmss.ss)	000000.00-235959.99
d2	Current day	01-31
d3	Current month	01-12
d4	Current year	0000-9999
d5	Local zone offset from UTC time (hour)	-13 to +13
d6	Local zone offset from UTC time (minutes)	00-59
*cc	Checksum	*00-*FF

Index

Symbols

"LOC" 30

"W84" 30

Numerics

1PPS 112

A

Access point (WiFi) 50

Accessories 4

ADL 33

ADLCONF 33

ADSL modem 54

ANH 95

Anonymous mode 48

ANR 95

Antenna (Bluetooth/WiFi) 9

Antenna (GNSS) 7

Antenna (GSM, external) 11

Antenna (UHF radio) 11

ATH 96

ATL 3

AUTO 28

Auto-calibration 72

Automatic power-on/off 23

Automatic receiver power-on/off 3

Automatic Transfer 85

Azimuth offset 21

B

Backup battery 13

Backup FTP server 85

BASE 28

Base data 77

Battery 24

Battery (external) 25

Battery Information 28

Battery model 13

Bottom mount 18, 19

BRV 64

BRV-1, BRV-2 74

Buzzer 14

C

Cellular antenna 11

Charger 25

Charging control (internal battery) 38

Client (WiFi) 50

Coaxial cables 7

Combining operating Modes 55

Convert G-files 83

D

Data Link Information 28

Data recording (out of sessions) 86

Default configuration 2

Delete Files After Transfer 85

Deleting files from memory 43

DGPS 28

Direct IP 33

Direction keys 26

Display screen 9

E

Earth connection 12

Electric isolation (optical) 12

Elevation offset 20

Email alerts 104

Embedded FTP server 92

Embedded NTRIP caster 87

Embedded NTRIP caster (current) 90

Embedded NTRIP caster (emulating Direct IP mode + protection) 88

Embedded NTRIP caster (history) 90

Embedded NTRIP caster (log) 90

Embedded NTRIP caster (settings) 89

Escape button 27

Ethernet 35, 51

Ethernet port 12

Event marker 113

Event marker input 113

Expiration date 117

External event 113

F

Factory settings 2

FEC 32

Firmware upgrade 115

Firmware upgrades 8

FIXED 28

Flex 72

FLOAT 28

FTP server (external) 85

Full Notification 104

Fuse 25

G

Gateway 53, 54

General Status screen 27

Geoid model 129, 132

GETID 96

GETMEM 96

GETPOS 97

GETPOWER 97

G-files 82, 83, 84, 85

GNSS input #1 11

GSM antenna 11

H

Hatanaka *83*
Heading *71*
HELP *98*
Host name *33*
Hub *53, 54*

I

Icons on General Status screen *27*
Install firmware option *116*
Instant RTK *108*
Insulation (electric) *12*
IP address on receiver identification screen *53*

L

LAN *53, 54*
Language *36*
LED (power) *10*
LOC *30*
Local settings *51*
Lug *18*

M

MEM *99*
Memory *43*
Memory Information *28*
MODE *99*
Modem Information *29*
Modem screen *33*
Mount point *33*
Mount points *87*
Mount points (protection) *91*
Move files *84*
Moving base *68*

N

Navigation data *83*
NMEA messages *79, 122*
No Notification *104*
NTRIP *33*
NTRIP servers (internal) *87*

O

Offset Per Day *82*
OK button *27*
OLED *9*
One-antenna configuration *56*
Options (firmware, pre-installed) *7*

P

Path *85*
PDL *33*
Pinouts *14, 15, 17*
POPN *8*
Port P *87*

Port Q *87*
POS *100*
Position Solution screen *30*
Power button *9*
Power cord *6*
Power mode *23*
Power Off screen *44*
PPS *112*
Primary FTP server *85*
Public IP address *54*

R

R port *82*
RADIO *101*
Radio screen *31*
Raw data recording *57, 78*
Raw Data Recording Information *28*
Raw data type *82*
REC *102*
Receiver Information screen *30*
Recording elevation mask *82*
Recording menu *86*
Reference Day *81*
Repeater *32*
Resetting the receiver *113*
RINEX *83*
Ring File memory *83*
RTK-1, RTK-2 *73*
RTX *61*

S

S DGPS *28*
SCR *32*
Scroll button *9*
SD Card, Bluetooth, USB information *29*
Security *47*
Semi-major axis *135*
Semi-minor axis *135*
SEND LOG *103*
SEND PAR *103*
Serial ports *12*
Sessions *28, 43, 80, 83, 84, 85*
SIM card *13*
Site name *43, 82*
Sleep mode *81*
SMA *11*
SMS (for remote control) *93*
SP File Manager *118*
SP File Manager (copy files) *120*
SP File Manager (delete files) *120*
SP Loader *114*
Standard Notification *104*
Status banner (Web Server) *3*

Storage medium *84*
Sub-directory Name Format *84, 85*
Survey Pro *3*
Switch *53, 54*

T

Trimble RTX subscription *117*
Tripod mount *18*
Two-antenna configuration *70*

U

UHF input *11*
UHF networking *121*
Upgrade procedure (firmware) *115*
Upgrade receiver firmware *115*
Upgrading firmware *45*
USB (OTG) *10*
USB device *83*
USB driver *10*
USB key *45*
USB port *10*
Users (NTRIP caster) *87*

V

VESA *19*
Virtual antenna *69*

W

W84 *30*
Warranty (end of) *117*
Web browser *47*
Web Server Status banner *3*
Welcome screen *26*
WiFi *34, 48*
WiFi Information *29*
WiFi key *35*
Workflow (User Interface) *26*

X

XDL *33*

SP90m GNSS Receiver

User Guide

Contact Information:

AMERICAS

10368 Westmoor Drive
Westminster, CO 80021, USA
+1-720-587-4700 Phone
888-477-7516 (Toll Free in USA)

EUROPE, MIDDLE EAST AND AFRICA

Rue Thomas Edison
ZAC de la Fleuriaye - CS 60433
44474 Carquefou (Nantes), France
+33 (0)2 28 09 38 00 Phone

ASIA-PACIFIC

80 Marine Parade Road
#22-06, Parkway Parade
Singapore 449269, Singapore
+65-6348-2212 Phone



www.spectraprecision.com

©2017-2018, Trimble Inc. All rights reserved. Spectra Precision and the Spectra Precision logo are trademarks of Trimble Inc. or its subsidiaries. All other trademarks are the property of their respective owners. (2018/01)